

# Montage™ 32FS

## Appliance Specifications

Product Reference Information			
Cat. No.	Model	Ship. Weight	Ship. Volume
H6839	Montage 32FS	285 lb.	22.06 cu. ft.

Flue Size	3" (76 mm) Rear
Floor Protection Requirements	Front & Sides: 6" (152 mm) Back: Up to 6" (152 mm) ❶
Hopper Capacity	55 Lbs. ❷
Burn time	15 - 37 hours ❷
Fuse, Control Board Fuse, Igniter	5 Amp, 250 volt, 3AG ❸ 6 Amp, 125 volt ❸
Heat Input (BTU's per hour)	13,000 - 32,000 BTU/hr ❷
Emissions	< 4.03 gr/hr EPA Certified
Efficiency	82%
Convection (room air) Blower	150 CFM; 1.5 Amps, 2175 rpm
Combustion Blower	95 CFM; 1.0 Amps, 3000 rpm
Auger Motor	1.25 RPM; 0.48 Amps
Standard Features	Fastfire™ Self Igniter Wall Thermostat (wire included)

### Notes:

- Dimensions shown are approximations only (+/- 1/4")
- Approved for Manufactured Home Installations.
- Optional Kits Available - Decorative trim kits, log set and 3" and 4" Quick Disconnect kits.
- The burn grate is designed with advanced UltraGrate™ technology.
- Diagrams, illustrations and photographs are not to scale – consult installation instructions. Product designs, materials, dimensions, specifications, colors and prices are subject to change or discontinuance without notice.

❶ In Canada floor protection is required directly underneath and 2" from the sides of the flue or chimney adapter. This is recommended in the US.

❷ Burn times, hopper capacity and BTU input may vary depending on the size and type of fuel used.

❸ Fuses are rated as fast acting.

## Freestanding Pellet Stove

## ELITE™ SERIES

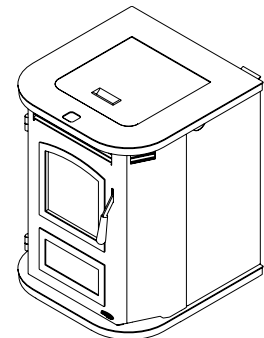
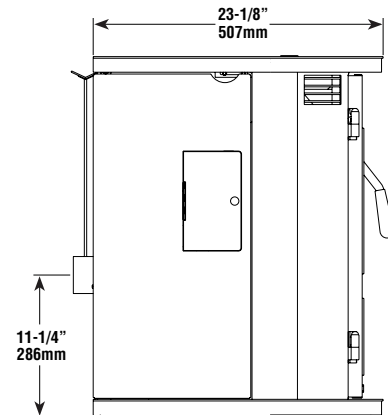
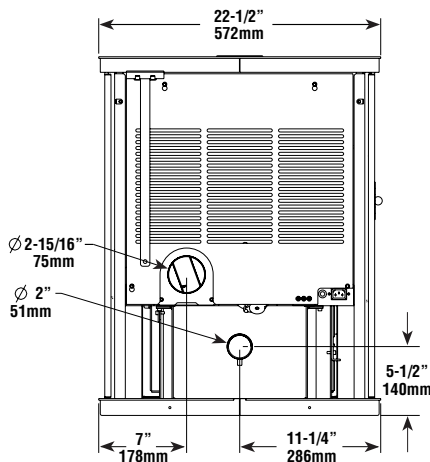
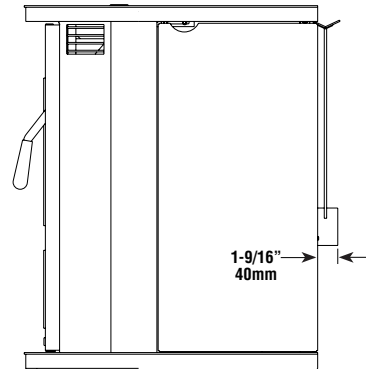
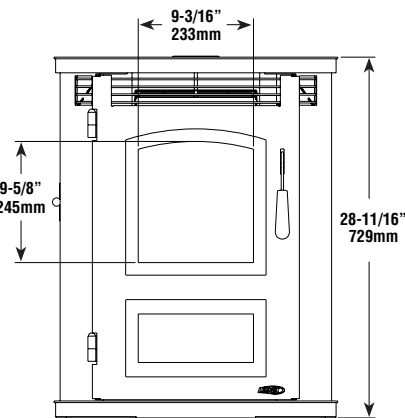
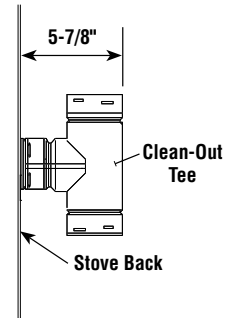
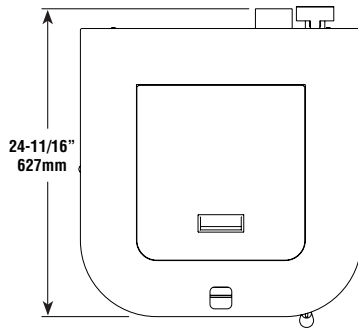

Report No. 3105656MID

Tested to/Testé selon:  
ASTM E-1509 / UL 1482 / ULC S627

# LENNOX™

HEARTH PRODUCTS

Diagrams & Illustrations Are Not to Scale

Page 1 of 2

# Montage™ 32FS

## FLOOR PROTECTION

A noncombustible floor protector must fully cover the area beneath the appliance and extend 6" to the front, 6" to the sides, and up to 6" from the back as illustrated.

*\*Note: When installed at clearances less than 6", the floor protection is only required to extend to the wall.*

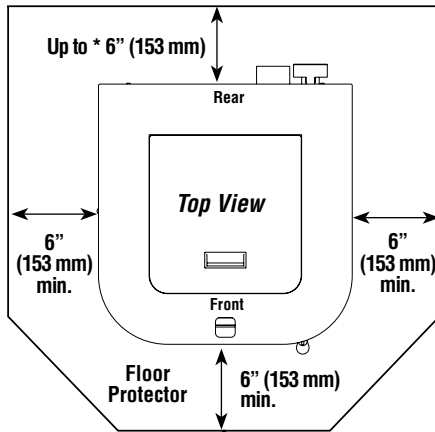

## CLEARANCES

Clearances to combustibles are determined from testing to applicable standards for allowable heat transfer. The clearances allowed as shown here, do not take into account operation or serviceability requirements.

Standard residential or manufactured home installation. These appliances require the following minimum clearances to combustibles:

### Minimum Clearances To Combustibles

MINIMUM CLEARANCES TO COMBUSTIBLE MATERIALS	
Freestanding Stove Installation, Manufactured (Mobile) Home Or Residential Installation	
A - Side wall to unit	4" (102 mm)
B - Back wall to unit	2" (51 mm)
C - Side wall to unit Corner	1" (25 mm)
D - Max. Depth of Alcove	① 24" (610 mm)
E - Flue to Wall	② 3" (76mm)
① Minimum Alcove Measurements - Height 48" (1220 mm) x Width 31" (788 mm) x Maximum Depth 24" (610 mm)	
② See vent manufacturer to verify clearances	

## VENTING CONFIGURATIONS

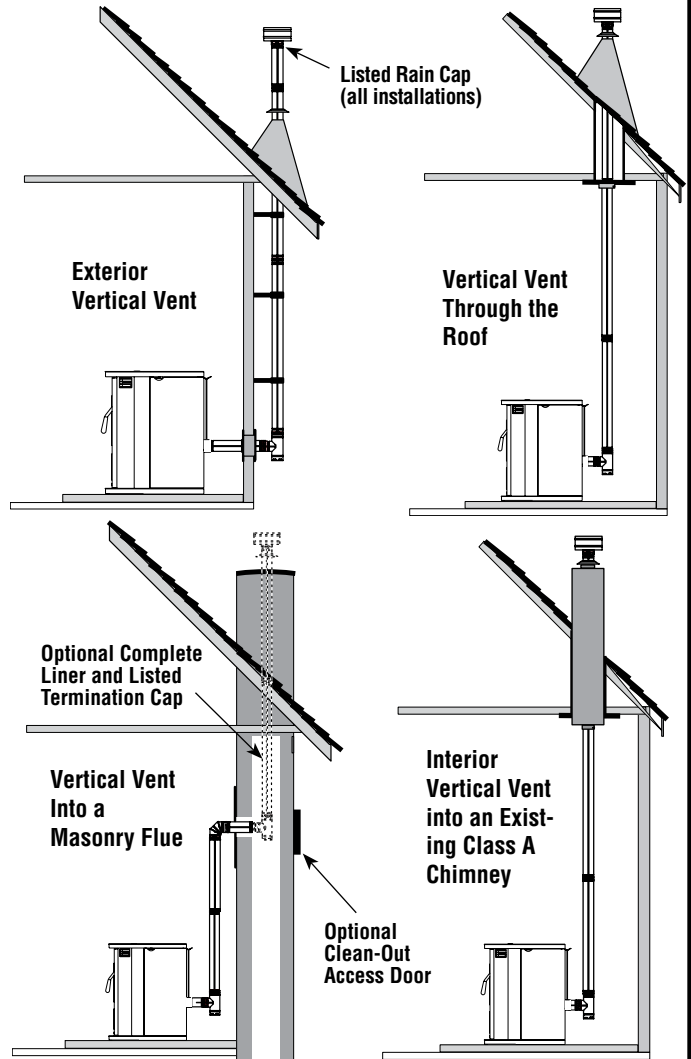

### IMPORTANT NOTES

- Minimum clearances specified may not allow for ease of operation and maintenance (please take this in to account when planning the installation). If installed to the minimum clearances, removal of the appliance may be necessary for servicing.
- Recommended clearance zone from the front of the appliance to combustibles is 4 feet minimum.

