



HEARTH PRODUCTS

HEARTH PRODUCTS
KITS AND ACCESSORIES

750,204M
REV. E 02/2010

**HORIZONTAL
TERMINATION**

INSTALLATION INSTRUCTIONS FOR SV4.5HTSS, SV4.5-20SSWSK AND ALL DERIVATIONS OF THE SF-HTSS; SFKIT12-SS, SFKIT18-SS, SFKIT24SS, SFKIT26SS & SFKIT48-SS

GENERAL INFORMATION

This document details installation instructions for the SV4.5HTSS, SV4.5-20SSWSK and all derivations of the SF-HTSS; SFKIT12-SS, SFKIT18-SS, SFKIT24-SS, SFKIT36-SS, and SFKIT48-SS. Information provided here is supplemental to instructions provided with each fireplace and may, for the most part, be redundant to that information. The intent of this document is to provide complete instructions pertaining to the installation of the before-mentioned terminations, particularly any instructions that are exclusive to the installations of these terminations.

The SV4.5HTSS, SV4.5-20SSWSK and all derivations of the SF-HTSS; SFKIT12-SS, SFKIT18-SS, SFKIT24-SS, SFKIT36-SS, and SFKIT48-SS are intended for use ONLY with Lennox and Superior branded 33" and 35" Direct-Vent gas fireplaces; SSDV-3328, SSDV-3530, SDV35N, LMDV3328, LMDV-3530, MPD-3328, MPD-3530, MPLDV-30 and MPLDV-35 models. These terminations **may not** be used with Lennox Spectra series, Elite EDV and ELDV series and Lennox and Superior branded Multi-View models.

The terminations covered by this document seamlessly integrate with all the other components of the above mentioned fireplaces approved for use with these terminations, and when installed in accordance with the directions provided here and with each fireplace constitute a complete, approved and listed installation.

These terminations have been tested and listed to ANSI Z21.88/CSA 2.33 by Omni Test Laboratories, Report Number 116-P-40D-5.

Framing

Frame the fireplace in accordance with the instructions provided with the fireplace and refer to **Figure 1** and **Figure 5** for any dimensions peculiar to the SV4.5HTSS, SF-HTSS.

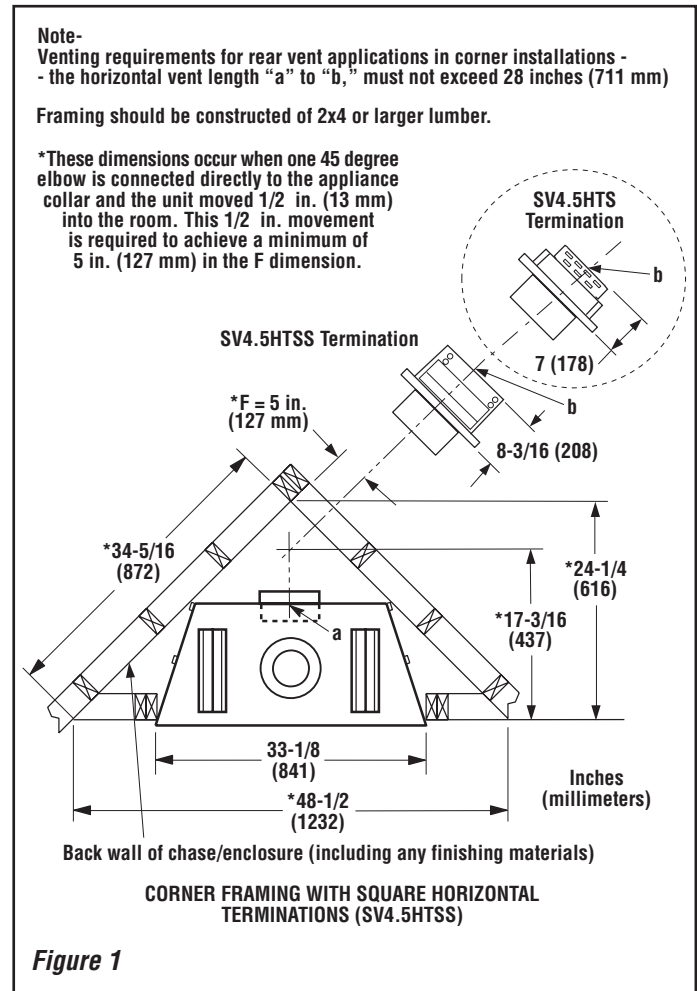

OTL Report No. 116-P-40D-5

HORIZONTAL (OUTSIDE WALL) TERMINATION SYSTEM

Figure 2, and Figures 7 to 13 and their associated Horizontal Vent Tables, illustrate the various horizontal venting configurations that are possible for use with these appliances. **Secure Vent** pipe applications are shown in these figures; **Secure Flex** pipe may also be used. A Horizontal Vent Table summarizes each system's minimum and maximum vertical and horizontal length values that can be used to design and install the vent components in a variety of applications. Both of these horizontal vent systems terminate through an outside wall. Building Codes limit or prohibit terminating in specific areas. Refer to the instructions provided with the fireplace.

Secure Vent SV4.5 direct vent system components are unitized concentric pipe components featuring positive twist lock connection.

A. Plan the vent run -

Analyze the vent routing and determine the types and quantities of sections required 4-1/2" (114 mm), 10-1/2" (267 mm), 22-1/2" (572 mm), 34-1/2" (876 mm) and 46-1/2" (1181 mm) net section lengths are available. Make allowances for elbows as indicated in the instructions provided with the fireplace. **Maintain a minimum 1" (25 mm) clearance to combustibles on the vertical sections. Clearances for the horizontal runs are; 3" (76 mm) on top, 1" (25 mm) on sides, and 1" (25 mm) at the bottom.**

B. Frame exterior wall opening -

Locate the center of the vent outlet on the exterior wall. Cut and/or frame an opening, 10-1/2" x 12-1/8" (267 mm x 308mm) inside dimensions, about this center.

C. Frame ceiling opening - If the vertical route is to penetrate a ceiling, use plumb line to locate the center above the appliance. Cut and/or frame an opening, 10-1/2" x 10-1/2" (267 mm x 267 mm) inside dimensions, about this center.

D. Attach vent components to appliance - To attach a vent component to the appliance collar, align the dimpled end over the collar, adjusting the radial alignment until the four locking dimples are aligned with the inlets of the four incline channels on the collar. Push the vent component against the collar until it fully engages, then twist the component clockwise, running the dimples down and along the incline channels until they seat at the end of the channels. The unitized design of the **Secure Vent** components will engage and seal both the inner and outer pipe elements with the same procedure.

Sealant and securing screws are not required.

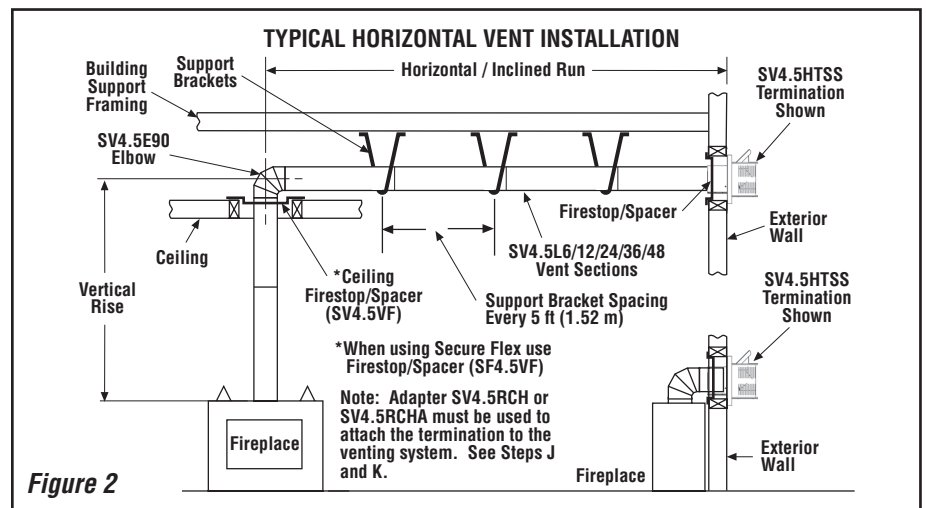

Note: An elbow may also be attached to the appliance collar. Attach in the same manner as you would a vent section.

E. Attach vent components to each other -

Other vent sections may be added to the previously installed section in accordance with the requirements of the vent tables. To add another vent component to a length of vent run, align the dimpled end of the component over the inclined channel end of the previously installed section, adjusting the radial alignment until the four locking dimples are aligned with the inlets of the four incline channels of the previous section. Push the vent component against the previous section until it fully engages, then twist the component clockwise running the dimples down and along the incline channels until they seat at the end of the channels.

F. Install firestop/spacer at ceiling -

When using Secure Vent, use SV4.5VF firestop/spacer at ceiling joists; when using Secure Flex, use SF4.5VF firestop/spacer. If there is living space above the ceiling level, the firestop/spacer must be installed on the bottom side of the ceiling. If attic space is above the ceiling, the firestop/spacer must be installed on the top side of the joist. Route the vent sections through the framed opening and secure the firestop/spacer with 8d nails or other appropriate fasteners at each corner.

Remember to maintain 1" (25 mm) clearance to combustibles, framing members, and attic or ceiling insulation when running vertical chimney sections.

G. Support the vertical run sections -

On the vertical run, support the venting system every 8 feet (2.4m) above the fireplace vent outlet with field provided support straps (Plumber's tape). Attach the straps to the vent pipe and secure to the framing members with nails or screws.

H. Change vent direction - At transition from or to a horizontal/inclined run, install the SV4.5E45 and SV4.5E90 elbows in the same manner as the straight vent sections. The elbows feature a twist section to allow them to be routed about the center axis of their initial collar section to align with the required direction of the next vent run element. **Twist elbow sections in a clockwise direction only so as to avoid the possibility of unlocking any of the previously connected vent sections.**

I. Continue installation of horizontal/inclined sections -

Continue with the installation of the straight vent sections in horizontal/inclined run as described in **Step E**. Install support straps every 5 ft. (1.52 m) along horizontal/inclined vent runs using conventional plumber's tape. See **Figure 2**. **It is very important that the horizontal/inclined run be maintained in a straight (no dips) and recommended to be in a slightly elevated plane, in a direction away from the fireplace of 1/4" rise per foot (20 mm per meter) which is ideal, though rise per foot run ratios that are smaller are acceptable all the way down to at or near level.** Use a carpenter's level to measure from a constant surface and adjust the support straps as necessary.

It is important to maintain the required clearances to combustibles: 1" (25 mm) at all sides for all vertical runs; and 3" (76 mm) at the top, 1" (25 mm) at sides, and 1" (25 mm) at the bottom for all horizontal/inclined runs.

J. Assemble vent run to exterior wall - If not previously measured, locate the center of the vent at the exterior wall. Prepare an opening as described in **Step B**

Square Horizontal Termination- (SV4.5 HTSS)

Assemble the venting system to a point where the terminus of the last section is within 6 in. (152mm) to 9 in. (228mm) inboard of the exterior surface to which the termination is to be attached, see **Figure 4**. Attach Adapter SV4.5RCH as shown in **Figure 3**.

If the terminus of the last section is not within this distance, use the **telescopic vent section SV4.5LA**, as the last vent section for up to 15-3/4 in. (400mm). For distance greater than 15-1/4 in. (400mm) use adapter SV4.5RCHA and refer to **Table 1**. This table lists venting components needed in addition to the termination adapter. Also refer to the vent section length chart in the fireplace installation instructions manual for help on selecting additional vent sections.

Square Horizontal Termination - (Kit No. SV4.5-20SSWSK)

Assemble the venting system to a point where the terminus of the last section is within 6 in. (152mm) to 21-1/4 in. (540mm) inboard of the exterior surface to which the termination is to be attached, see **Figure 5**. Attach Adapter SV4.5RCHA as shown in **Figure 3**. Go to **Step K** for cutting to length instructions.

K. Attach Termination Adapter - Square Horizontal Termination Kit SV4.5HTSS (with short adapter)

Attach adapter **SV4.5RCH** (provided with the termination kit), to the vent section or telescoping vent section, elbow or appliance collar as shown in **Figure 3**, in the same manner as any SV4.5 vent component (refer to **Step E**).

Square Horizontal Termination Kit SV4.5-20SSWSK (with short adapter)

Attach adapter **SV4.5RCHA** (provided with the termination kit No. SV4.5-20SSWSK), to the vent section or telescoping vent section, elbow or appliance collar as shown in **Figure 3**, in the same manner as any SV4.5 vent component (refer to **Step E**).

It may be necessary to cut the excess length from the adapter. Measure the distance from the last venting section to the exterior surface to which the termination is to be attached, see **Figure 3**. This is the total length the adapter must be.

- a) Separate the inner and outer pipes from the adapter.
- b) Mark the desired length of the outer pipe measured from the dimpled end towards the plain end.
- c) Cut the excess material with sheet metal scissors or similar tool.

d) Proceed to mark the inner pipe using the same dimension for the outer pipe, it is recommended to add 1/4" to the length to aid in catching the mating pipe when inserting the termination.

L. Install Firestop/Spacer at exterior wall - When using either of the **square** terminations, install SV4.5HF (Secure Vent), or SF4.5HF (Secure Flex) firestop/spacer over the opening at the exterior side of the framing, long side up, with the 3 inch spacer clearance at the top as shown in **Figure 3**, and nail into place. (The Firestop/Spacer may be installed over the opening at the interior side of the framing).

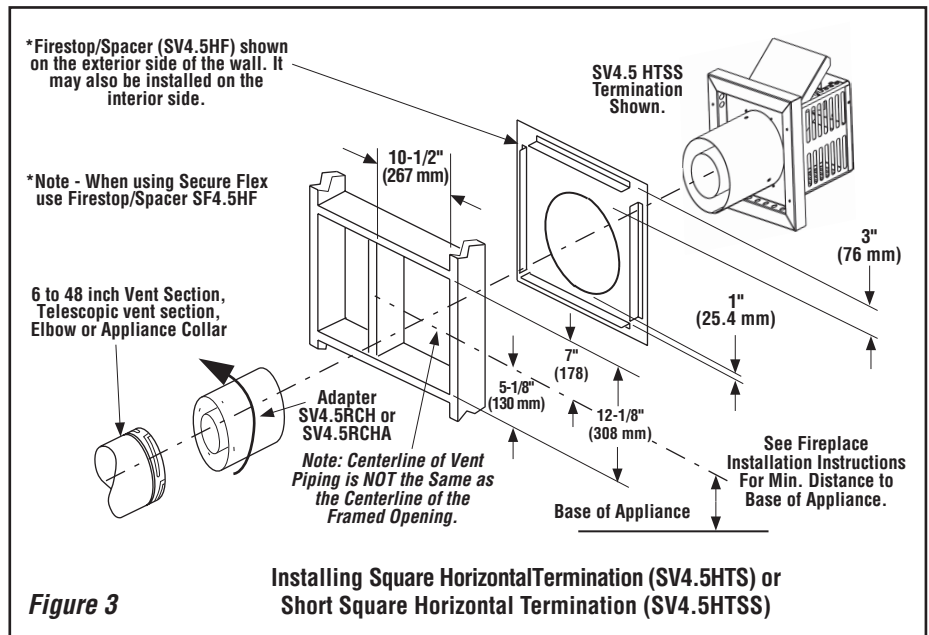

Figure 3

Installing Square Horizontal Termination (SV4.5HTS) or Short Square Horizontal Termination (SV4.5HTSS)

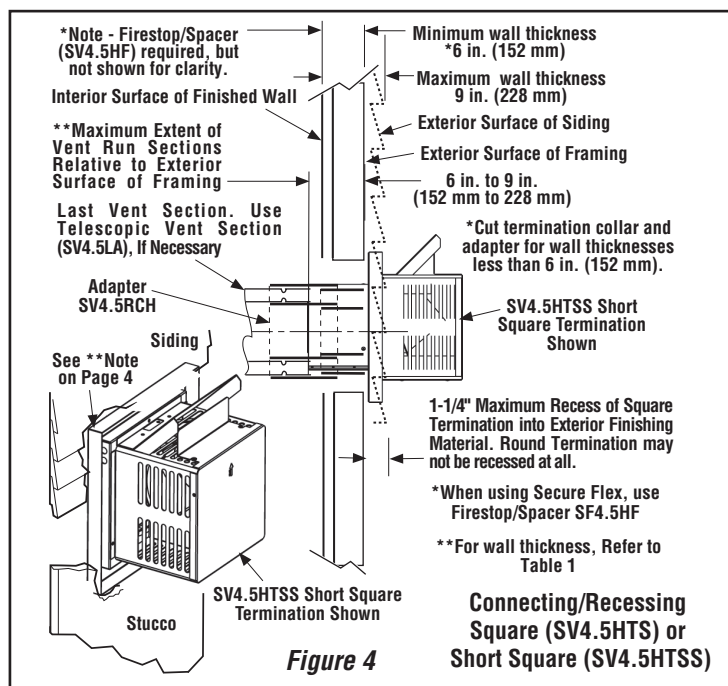

Figure 4

Connecting/Recessing Square (SV4.5HTS) or Short Square (SV4.5HTSS)

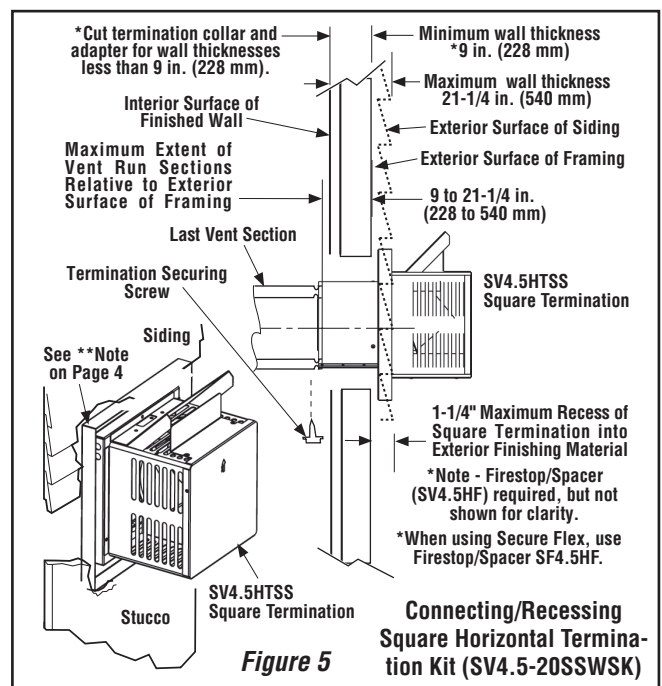

Figure 5

Connecting/Recessing Square Horizontal Termination Kit (SV4.5-20SSWSK)

M. Install the desired termination -

1. Install the short square termination (SV4.5HTSS) - For the last step, from outside the exterior wall, slide the collars of the termination into the adapter (see *Figure 4*) until the termination seats against the exterior wall surface to which it will be attached. Orient the housing of the termination with the arrow pointed upwards. Secure the termination to the exterior wall.

The horizontal termination must not be recessed into the exterior wall or siding by more than the 1-1/4" (32 mm) as shown in *Figure 4*.

2. Install the square termination (SV4.5HTSS) - For the last step, from outside the exterior wall, slide the collars of the termination onto the last vent section (see *Figure 5*) until the termination seats against the exterior wall surface to which it will be attached.

Orient the housing of the termination with the arrow pointed upwards. Secure the termination to the exterior wall. **The horizontal termination must not be recessed into the exterior wall or siding** by more than the 1-1/4" (32 mm) as shown in *Figure 5*.

****Note:** To prevent water infiltration in wet environments, we recommend the use of a silicone sealant between the termination and the wall. (Refer to *Figure 4* and *Figure 5*).

HORIZONTAL VENT FIGURES/TABLES

TABLE 1 - Venting Components Required for Various Exterior Wall Thicknesses, When Using Any of These Termination Kits - Square Termination (SV4.5HT) Small Square Termination (SV4.5HTSS)	
Venting Components Required	Exterior Wall Thicknesses inches (mm)
Termination Kit Only	6 to 9 (152 to 228)
Termination Kit and 6 in. vent section (SV4.5L6)	10 1/2 to 13 1/4 (267 to 337)
Termination Kit and 12 in. vent section (SV4.5L12)	16 3/4 to *17 1/2 (425 to *495)
Termination with 20" adapter SV4.5RCHA	9" (228 mm) to 21-1/4" (540 mm)
Termination Kit and Telescopic section (SV4.5LA) and 6 in. vent section (SV4.5L6)	12 to *21 1/4 (305 to *540)

***Note:** See *Figure 7* for wall thickness range reductions when using SV4.5HTS and SV4.5HTSS terminations.

Note: *Secure Vent* components (rigid vent pipe and terminal) are shown in the figures; *Secure Flex* components (flexible vent pipe and terminal) may also be used.

Note: SV4.5VF (Secure Vent), SF4.5VF (Secure Flex) firestop/spacer must be used anytime vent pipe passes through a combustibile floor or ceiling. SV4.5HF (Secure Vent), SF4.5HF (Secure Flex) firestop/spacer must be used anytime vent pipe passes through a combustibile wall.

Note: Two 45 degree elbows may be used in place of one 90 degree elbow. The same rise to run ratios, as shown in the venting figures for 90 elbows, must be followed if 45 degree elbows are used.

Note: It is very important that the horizontal/inclined run be maintained in a straight (no dips) and recommended to be in a slightly elevated plane, in a direction away from the fireplace of 1/4" rise per foot (20 mm per meter) which is ideal, though rise per foot run ratios that are smaller are acceptable all the way down to at or near level.

WARNING: UNDER NO CIRCUMSTANCES MAY SEPARATE SECTIONS OF CONCENTRIC FLEXIBLE VENT PIPE BE JOINED TOGETHER.

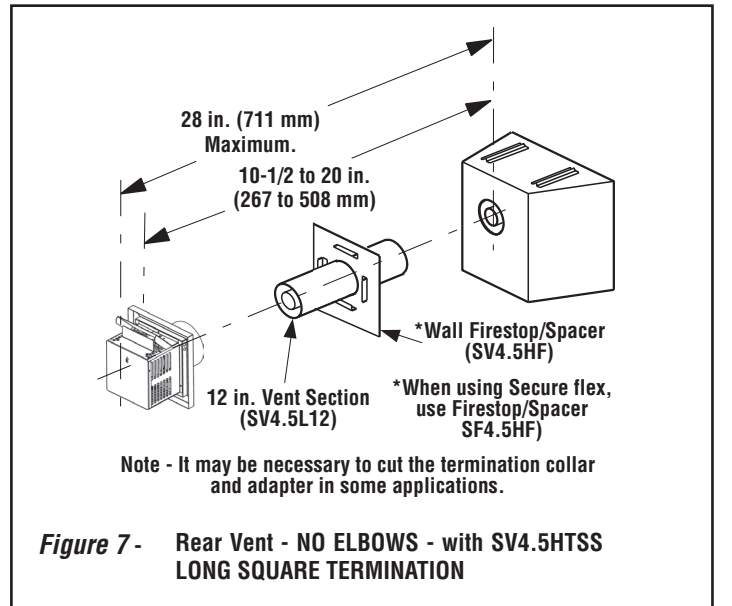
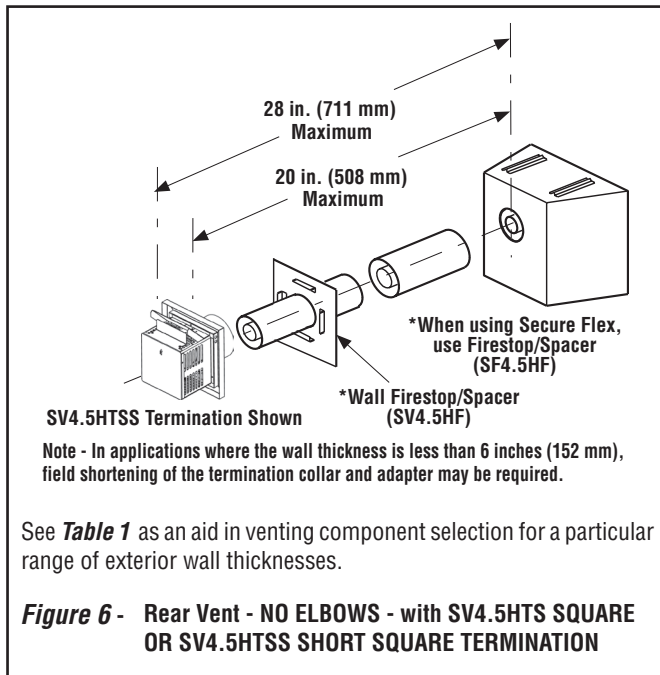

HORIZONTAL VENT FIGURES/TABLES (CONTINUED)

TABLE A

V = One 90 degree elbow
H = 3 feet (0.914 m) Max.

Refer to **Table 1** for an aid in venting component selection for a particular range of exterior wall thicknesses when using the square (SV4.5HTS) or small square (SV4.5HTSS).

Short Square Termination (SV4.5HTSS) shown; SV4.5-20SSWSK and SV4.5HT may also be used.

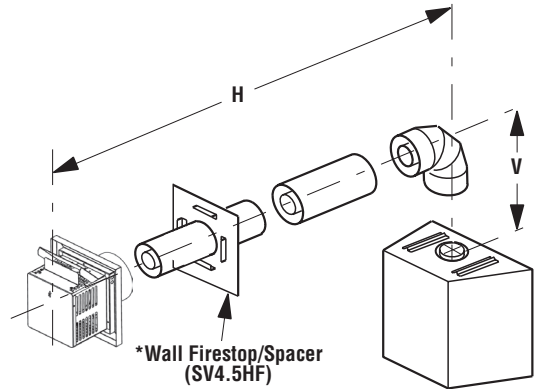

*When using Secure Flex, use Wall Firestop/Spacer SV4.5HF.

Figure 8 - Top Vent - ONE 90 DEGREE ELBOW - ELBOW CONNECTION AT APPLIANCE

TABLE B

V Minimum		H Maximum	
feet	(m)	feet	(m)
1	(0.305)	5	(1.52)
2	(0.61)	10	(3.1)
3	(0.914)	15	(4.65)
4	(1.22)	20	(6.2)

V + H = 40 feet (12.4 m) Max.
H = 20 feet (6.2 m) Max.

Refer to **Table 1** for an aid in venting component selection for a particular range of exterior wall thicknesses when using the square (SV4.5HTS) or small square (SV4.5HTSS).

Short Square Termination (SV4.5HTSS) shown; SV4.5-20SSWSK and SV4.5HT may also be used.

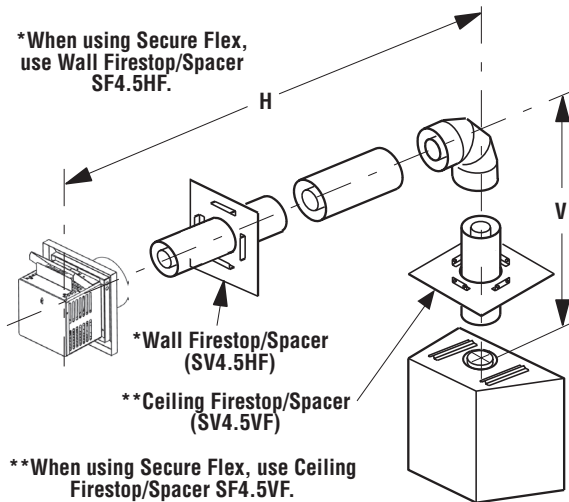

*When using Secure Flex, use Wall Firestop/Spacer SF4.5HF.

*Wall Firestop/Spacer (SV4.5HF)

**Ceiling Firestop/Spacer (SV4.5VF)

**When using Secure Flex, use Ceiling Firestop/Spacer SF4.5VF.

Figure 9 - Top Vent - ONE 90 DEGREE ELBOW - ELBOW CONNECTION NOT DIRECTLY AT APPLIANCE

TABLE C

V Minimum		H Maximum		H+H ₁ Maximum	
feet	(m)	feet	(m)	feet	(m)
1	(0.305)	2	(0.610)	5	(1.52)
2	(0.610)	4	(1.22)	10	(3.1)
3	(0.914)	6	(1.86)	15	(4.65)
4	(1.22)	8	(2.48)	20	(6.2)

V+H+H₁ = 40 feet (12.4 m) Max.
H = 8 feet (2.48 m) Max.
H + H₁ = 20 feet (6.2 m) Max.

Refer to **Table 1** for an aid in venting component selection for a particular range of exterior wall thicknesses when using the square (SV4.5HTS) or small square (SV4.5HTSS).

Short Square Termination (SV4.5HTSS) shown; SV4.5-20SSWSK and SV4.5HT may also be used.

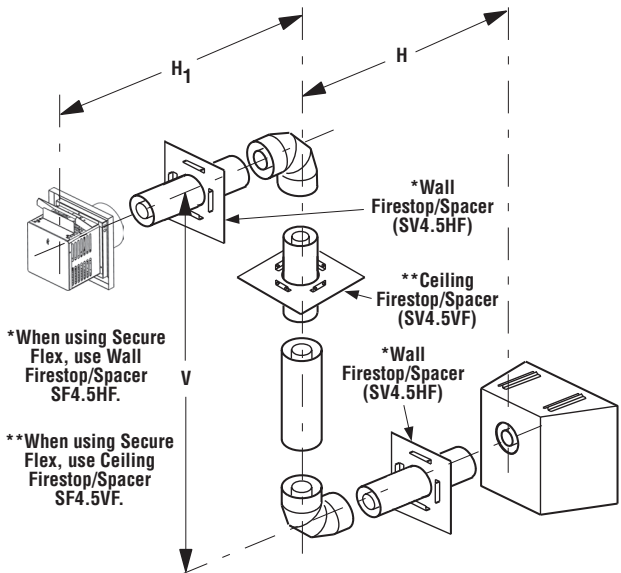

*When using Secure Flex, use Wall Firestop/Spacer SF4.5HF.

*Wall Firestop/Spacer (SV4.5HF)

**Ceiling Firestop/Spacer (SV4.5VF)

**When using Secure Flex, use Ceiling Firestop/Spacer SF4.5VF.

Figure 10 - Rear Vent - TWO 90 DEGREE ELBOWS

HORIZONTAL VENT FIGURES/TABLE (CONTINUED)

TABLE D			
V MINIMUM		H + H₁ Maximum	
feet	(m)	feet	(m)
1	(0.305)	5	(1.52)
2	(0.610)	10	(3.1)
3	(0.914)	15	(4.65)
4	(1.22)	20	(6.2)
V + H + H ₁ = 40 feet (12.4 m) Max. H + H ₁ = 20 feet (6.2 m) Max.			

Short Square Termination (SV4.5HTSS) shown; SV4.5-20SSWSK and SV4.5HT may also be used.

Figure 11- Top Vent - TWO 90 DEGREE ELBOWS

Refer to **Table 1** for an aid in venting component selection for a particular range of exterior wall thicknesses when using the square (SV4.5HTS) or small square (SV4.5HTSS).

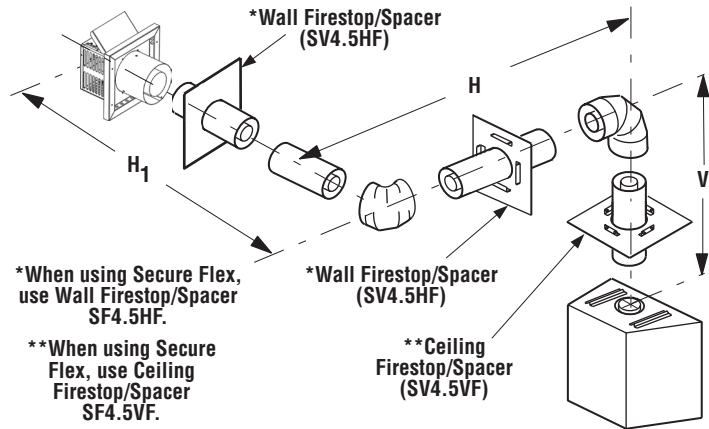

TABLE E					
V Minimum		H Maximum		H+H₁+H₂ Maximum	
feet	(m)	feet	(m)	feet	(m)
1	(0.305)	2	(0.610)	5	(1.52)
2	(0.610)	4	(1.22)	10	(3.1)
3	(0.914)	6	(1.86)	15	(4.65)
4	(1.22)	8	(2.48)	20	(6.2)
V+H+H ₁ +H ₂ = 40 feet (12.4 m) Max. H = 8 feet (2.48 m) Max. H+H ₁ +H ₂ = 20 feet (6.2 m) Max.					

Refer to **Table 1** for an aid in venting component selection for a particular range of exterior wall thicknesses when using the square (SV4.5HTS) or small square (SV4.5HTSS).

Short Square Termination (SV4.5HTSS) shown; SV4.5-20SSWSK and SV4.5HT may also be used.

Figure 12 - Rear Vent - THREE 90 DEGREE ELBOWS

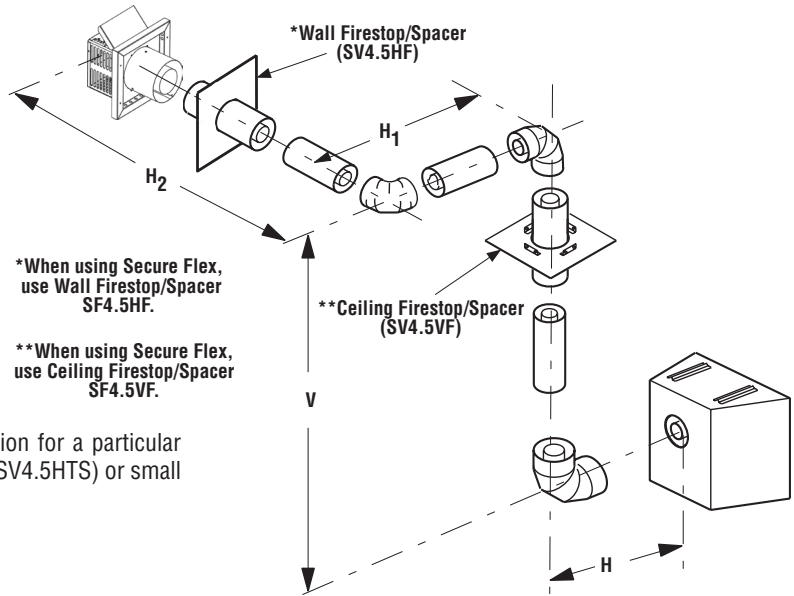
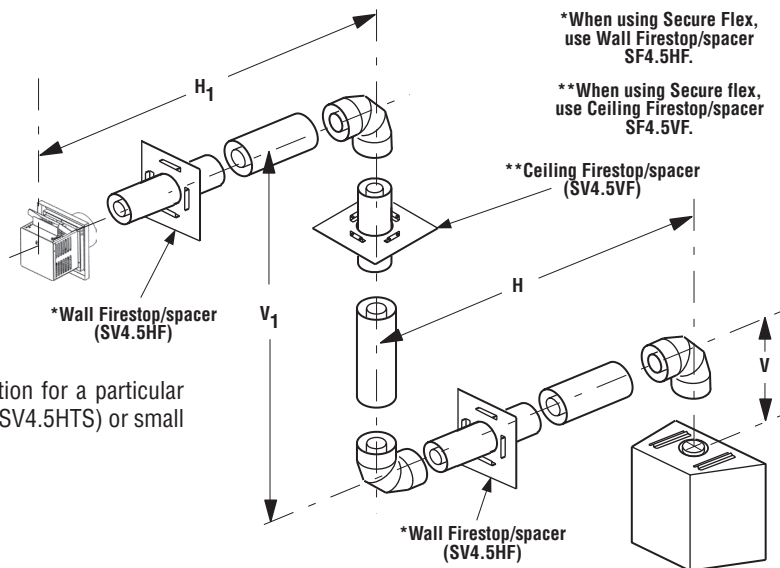

TABLE F			
V MINIMUM		H Maximum	
feet	(m)	feet	(m)
1	(0.305)	5	(1.52)
2	(0.610)	10	(3.1)
3	(0.914)	15	(4.65)
4	(1.22)	20	(6.2)
H + H ₁ = 20 feet (6.2 m) Max. V + V ₁ + H + H ₁ = 40 feet (12.4 m) Max.			

Refer to **Table 1** for an aid in venting component selection for a particular range of exterior wall thicknesses when using the square (SV4.5HTS) or small square (SV4.5HTSS).

Short Square Termination (SV4.5HTSS) shown; SV4.5-20SSWSK and SV4.5HT may also be used.

Figure 13 - Top Vent - THREE 90 DEGREE ELBOWS



VERTICAL OR HORIZONTAL VENTING USING SECURE FLEX KITS AND COMPONENTS

Secure Flex venting kits and components may be used in any venting application where rigid **Secure Vent** (SV4.5) direct vent components can be used. All restrictions, clearances and allowances that pertain to the rigid piping apply to the flexible venting. **Secure Flex kits may not be modified; also, under no circumstances may separate sections of flex pipe be joined together.** **Secure Flex** kits may be added to the end of a vent run made up of rigid **Secure Vent** (SV4.5) vent sections provided that doing so does not violate any of the venting length, height, routing, horizontal to vertical ratio requirements or clearance considerations detailed in this manual.

Secure Flex kits come with an included adapter that can be fitted to the appliance collar or the inclined channel end of the last **Secure Vent** (SV4.5) vent section in a rigid system in the exact same fashion as any other **Secure Vent** section. Align the dimpled end of the adapter over the previously installed section or appliance collar, adjusting the radial alignment until the four locking dimples of the adapter are aligned with the inlets of the four incline channels of the last vent section or collar. Push on the adapter until it fully engages, then twist the adapter clockwise running the dimples down and along the incline channels until they seat at the end of the channels.

Attach the flexible vent to the adapter as follows (see also Figure 14):

A. Install the Inner Flex Pipe -

1. Install the small gear clamp loosely around the inner flexible vent pipe, push it back out of the way.

2. Apply a bead of **Mill-Pac Black (700°F) high temperature sealant - Catalog No. 10K81** to the inner adapter collar, approximately 1/2 inch from the end.

3. Pull and extend the inner flexible vent pipe.

4. Slide the inner flex pipe over the adapter collar. Ensure the flexible vent pipe completely engages the adapter collar to a distance of 1-3/4 inches from the end, and that it is free from damage or tears.

5. Slide the gear clamp down and tighten it fully to secure the flexible vent to the adapter inner collar approximately 3/4 inch from the end of the flex.

6. Install **three screws 120 degrees apart** through the flexible vent pipe and into the adapter collar just below the gear clamp to provide additional security to the connection.

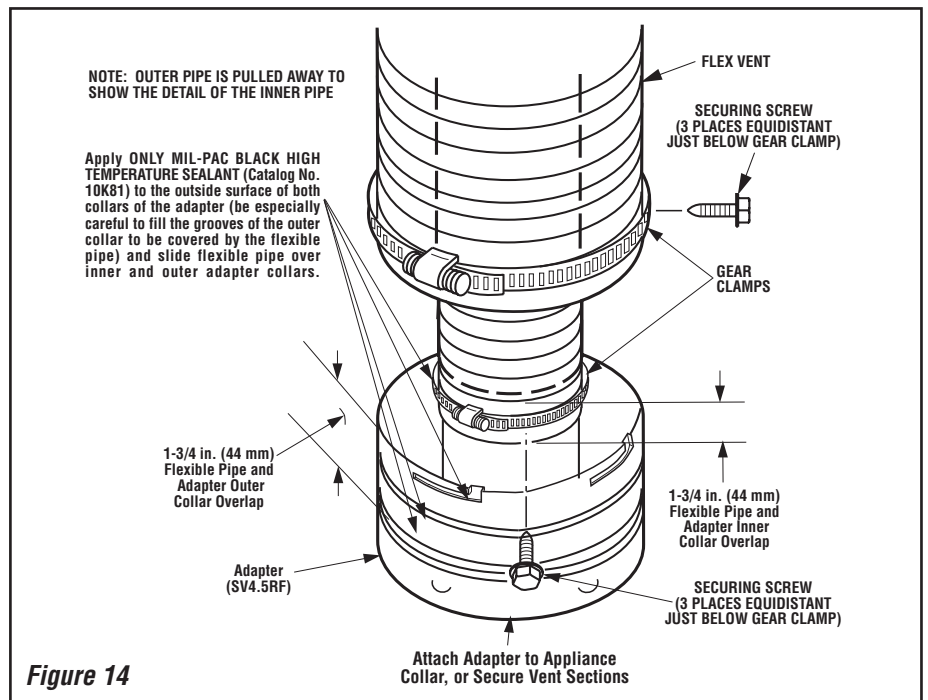

Figure 14

B. Install the Outer Flex Pipe -

1. Install the large gear clamp loosely around the outer flexible vent pipe, push it back out of the way.

2. Apply a bead of **Mill-Pac Black (700°F) high temperature sealant - Catalog No. 10K81** to the outer adapter collar; to the grooves of the collar which extend approximately 1 inch from the end and to the flat surface, approximately 1-3/8 inches from the end.

3. Pull and extend the outer flexible vent pipe.

4. Slide the outer flex pipe over the adapter collar. Ensure the flexible vent pipe completely engages the adapter collar to a distance of 1-3/4 inches from the end, and that it is free from damage or tears.

5. Slide the gear clamp down and tighten it fully to secure the flexible vent to the adapter outer collar approximately 3/4 inch from the end of the flex.

6. Install **three screws 120 degrees apart** through the flexible vent pipe and into the adapter collar just below the gear clamp to provide additional security to the connection.

C. Route Flex Vent -

Ensure that the flex vent is properly routed to provide the required clearance. Do Not allow the flexible vent to bend in a radius tighter than 5" (127 mm). Refer to **Figure 15**. Support horizontal sections of flex with metal straps at 2 foot (0.61 m) intervals.

D. Install Firestop/Spacers at ceilings and walls -

When **Secure Flex** penetrates a wall or ceiling, a firestop/spacer is required: use the SF4.5 VF firestop/spacer for ceilings and the SF4.5 HF firestop/spacer for walls. See the appropriate sections and figures shown throughout the venting section for their installation requirements.

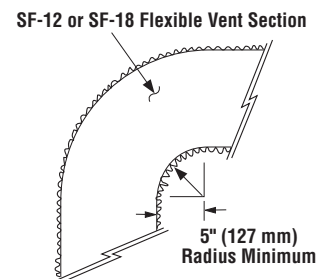

Figure 15

E. Attach Flex Vent to Termination -

Secure Flex components can be purchased separately and attached to bulk lengths of **Secure Flex** flexible tubing cut to size at the job site. Secure the flexible vent to the **Secure Flex** terminations in the same manner (see **Figure 14**) as it was attached to the adapter.

Note: Secure Flex vent must be attached to Secure Flex terminations only. DO NOT substitute Secure Vent terminations or the Secure Vent adapter for Secure Flex components. The collars of Secure Flex terminations and adapters have a different circumference than that used with the Secure Vent pipe. Additionally, Secure Flex components have an extended length center tube for use in attaching the flexible vent.

Lennox Hearth Products reserves the right to make changes at any time, without notice, in design, materials, specifications, prices and also to discontinue colors, styles and products. Consult your local distributor for fireplace code information.



HEARTH PRODUCTS

Printed in U.S.A. © 2005 by Lennox Hearth Products

P/N 750,204M REV. E 02/2010

1508 Elm Hill Pike, Suite 108 • Nashville, TN 37210