



HEARTH PRODUCTS



**RETAIN THESE INSTRUCTIONS
FOR FUTURE REFERENCE**

**VEUILLEZ GARDER CE MANUEL
POUR RÉFÉRENCE FUTURE.**

A French manual is available upon request. Order P/N 850,031CF

Ce manuel d'installation est disponible en français, simplement en faire la demande. Numéro de la pièce 850,031CF.

**NATIONAL
FIREPLACE
INSTITUTE**



CERTIFIED
www.nficertified.org

We recommend that our woodburning hearth products be installed and serviced by professionals who are certified in the U.S. by the National Fireplace Institute® (NFI) as NFI Woodburning Specialists or who are certified in Canada by Wood Energy Technical Training (WETT).



Tested &
Listed By



Beaverton
Oregon USA

OTL Report No.
116-F-37-2

OMNI-Test Laboratories, Inc.

INSTALLATION INSTRUCTIONS

MERIT® PLUS SERIES

42" Indoor / Outdoor Wood Burning Fireplaces
P/N 850,031M REV. B 04/2006

MODEL

MP-420D

This installation manual will enable you to obtain a safe, efficient and dependable installation of your fireplace system. Please read and understand these instructions before beginning your installation.

Do not alter or modify the fireplace or its components under any circumstances. Any modification or alteration of the fireplace system, including but not limited to the fireplace, chimney components and accessories, may void the warranty, listings and approvals of this system and could result in an unsafe and potentially dangerous installation.

IMPORTANT! TO ASSURE PROPER ALIGNMENT OF GLASS DOORS: INSTALL THIS FIREPLACE IN A SQUARE AND PLUMB CONDITION, USING SHIMS AS NECESSARY AT SIDES AND/OR BOTTOM.

NOTE: This fireplace has been listed and approved for use outdoors or indoors.

CAUTION! THIS FIREPLACE IS EQUIPPED TO BE READILY INSTALLED OUTDOORS. IF INSTALLED INDOORS, YOU MUST INSTALL THE COMBUSTION AIR COVER PROVIDED WITH THE INSTALLATION KIT OR PURCHASE THE OPTIONAL OUTSIDE AIR KIT GATE OAKG-OD. SEE INSTRUCTIONS INSIDE THIS MANUAL FOR FURTHER DETAILS.

IMPORTANT! POUR ASSURER L'ALIGNEMENT APPROPRIÉ DES PORTES DE VERRE : INSTALLEZ CE FOYER SUR UNE SURFACE PLANE ET METTRE À NIVEAU EN UTILISANT DES CALES AU BESOIN SUR LES CÔTÉS OU EN DESSOUS.

ATTENTION! CETTE CHEMINÉE A ÉTÉ ÉNUMÉRÉE ET APPROUVÉE POUR ÊTRE AISÉMENT INSTALLÉE À L'INTÉRIEUR OU DEHORS. S'INSTALLÉ À L'INTÉRIEUR, VOUS DEVEZ INSTALLER LA COUVERTURE D'AIR DE COMBUSTION ÉQUIPÉE DE KIT D'INSTALLATION OU ACHETER LA PORTE EXTÉRIEURE FACULTATIVE OAKG-OD DE KIT D'AIR. VOIR LES INSTRUCTIONS À L'INTÉRIEUR DE CE MANUEL POUR D'AUTRES DÉTAILS.

TABLE OF CONTENTS

Safety Rules.....	Page 2
Tools and Building Supplies.....	Page 2
Precautions.....	Page 2
Introduction.....	Page 3
Clearances/Height Requirements.....	Page 4
Chimney System.....	Page 4
Assembly Outline.....	Page 4
Location of Fireplace.....	Page 5
Clearances.....	Page 5
Assembly Steps.....	Page 6
Preinstallation Notes.....	Page 6
Waterproofing Fireplace.....	Page 6
Outside Air Kit.....	Page 6
Fireplace & Framing Specifications.....	Page 9
Installing the Fireplace.....	Page 10
Installing the Chimney System.....	Page 12
30° Offset through Floor/Ceiling.....	Page 13
Ten Foot Rule Summary.....	Page 15
Multiple Terminations.....	Page 15
Chimney Component Calculations.....	Page 15
Special Offset Instructions.....	Page 15
Offset Calculations.....	Page 16
Vertical Elevation Charts.....	Page 15
Installing Offsets.....	Page 16
Offset Elevation Chart.....	Page 18
Gas Line Connection.....	Page 18
Vent Free Appliances.....	Page 19
Glass Doors.....	Page 19
Cold Climate Insulation.....	Page 20
Fireplace Finishes - Mantels and Trim.....	Page 20
Hearth Extensions/Wall Shields.....	Page 20
Finish Requirements.....	Page 22
Installation Components.....	Page 23

PACKAGING

The assembled indoor/outdoor fireplace is packaged with:

- 1 - One envelope containing the literature package which consists of the homeowner's manual, installation instructions, warranty and combustion air cover (located in the firebox).
- 2 - One Outside Air Kit.
- 3 - Hearth Extension Strips.

PLEASE READ AND UNDERSTAND THESE IMPORTANT SAFETY RULES.

WARNING

To avoid the risk of damaging fireplace materials and increasing the risk of fire, do not use the fireplace to cook or warm food.

AVERTISSEMENT

Pour éviter le risque d'endommager les matériaux du foyer et d'augmenter le risque d'incendie, n'employez pas le foyer pour faire cuire ou réchauffer de la nourriture.

1. Before starting your fireplace installation, read these installation instructions carefully to be sure you understand them completely and in entirety. Failure to follow them could cause a fireplace malfunction resulting in serious injury and/or property damage.
2. Always check your local building codes. The installation must comply with all local, regional, state and national codes and regulations.
3. This fireplace must be installed with Security Chimneys FTF8 [8" (203mm) inside diameter] Chimney System only. This fireplace is intended for indoor or outdoor installations. The chimney system must always vent to the outside of the building or structure.
4. To ensure a safe fireplace system and to prevent the build-up of soot and creosote, inspect and clean the fireplace and chimney prior to use and periodically during the heating season.
5. Burn approved fuels only as defined in the Homeowner's Care and Operation Manual.
6. NEVER use gasoline, gasoline-type lantern fuel, kerosene, charcoal lighter fluid, or similar liquids to start or "freshen up" a fire in this fireplace. Keep any flammable liquids at safe distance from the fireplace.
7. NEVER leave children unattended when there is a fire burning in the fireplace.
8. Always keep flue damper open when heat is present in the fireplace.
9. Before servicing, allow the fireplace to cool. Always shut off any gas to the fireplace while working on it. This will prevent the possibility of burns.
10. This fireplace is not a heater. It is designed to ensure homeowner comfort by providing supplemental heat to its immediate area.
11. Keep screens closed after feeding fire to keep embers from flying out of fireplace.
12. **INDOOR INSTALLATIONS:**
 - Always ensure that an adequate supply of replacement combustion air from the outside of the house is accessible to the fire to support normal combustion. Fireplaces consume large volumes of air during the normal combustion process.
 - In the event the home is tightly sealed with modern energy efficient features, the optional outside air kit may not provide all the air required to support combustion.

- The manufacturer is not responsible for any smoking or related problems that may result from the lack of adequate combustion air. It is the responsibility of the builder/contractor to ensure that adequate combustion air has been provided for the fireplace.

- An *Outside Air Cover* (provided) or an *Outside Air Kit Gate, model OAKG-OD* (optional) must be installed to prevent significant cold air infiltration.

13. Always ensure that the air inlet to the fireplace is free from debris and any other obstructions that can block the entrance of air.
14. DO NOT use a fireplace insert or any other product not specified by Lennox for use with this fireplace. All gas log sets must be operated with the damper clamped open, including unlisted "vent free" log sets. Listed "vent-free" log sets may be operated with the damper closed.
15. "Smoke free" operation is not warranted nor are we responsible for inadequate system draft, general construction conditions, inadequate chimney heights, adverse wind conditions and/or unusual environmental factors or conditions beyond our control.
16. Never, under any circumstances, install a fireplace, chimney component or any accessories, that has visible or suspected physical damage as a result of handling or transportation. These items should be inspected by your distributor or qualified factory representative to ensure safe condition. When in doubt, consult your distributor.
17. For additional safety considerations and complete operating instructions, refer to the Care and Operation Manual provided with the fireplace.

TOOLS AND BUILDING SUPPLIES NORMALLY REQUIRED

Tools	Supplies
Phillips screwdriver	Framing materials
Hammer	Wall finishing materials
Saw and/or sabersaw	Caulking materials
Level	(noncombustible)
Measuring tape	Fireplace surround and
Plumb line	hearth extension
Electric drill and bits	materials
Pliers	(noncombustible)
Square	

PRECAUTIONS

The most important areas of concern dealing with the installation of factory-built fireplaces are clearances to combustible materials, proper assembly of component parts, height of the chimney system, the proper use of accessories supplied by the manufacturer and the techniques employed in using finishing materials applied to the wall surrounding the fireplace, hearth extensions and wall shields. Each of these topics will be covered in thorough detail throughout this manual. Please give each your special attention as you progress with your installation.

Note: These fireplace systems are not difficult to install. However, in the interest of safety, it is recommended that the installer be a qualified or certified "tradesman" familiar with commonly accepted fireplace installation and safety techniques as well as prevailing local codes.

INTRODUCTION

General Information

These fireplaces are traditional radiant heat fireplaces with standard bar grates, optional Outside Air Kits (required for outdoor installations) and optional Operable Bi-Fold Stainless Outdoor Glass Doors and Weather Cover.

These appliances are approved for installation indoors or outdoors.

Indoors: These appliances are approved for installation in residential homes and other buildings of conventional construction including commercial, not in manufactured homes (see **Figure 5**).

Outdoors: These appliances are approved for installation against an outside wall of a house, or as a freestanding fireplace on the porch, patio, or located in the yard (see **Figure 6**). The Outdoor Fireplace must be enclosed to prevent impact damage to the outside of the fireplace. Build an outside enclosure out of standard building materials, being careful to maintain the minimum air clearances specified in these Installation Instructions. When installing the fireplace as a freestanding unit on your porch, patio or backyard, it must also be enclosed to prevent impact damage to the fireplace. However, the enclosure must now be finished on all four (4) sides. The exterior of the enclosure may be finished in a textured plywood, a wood clapboard siding, brick, or a cultured stone.

Vinyl siding is not recommended for use on the front of the fireplace due to the heat the unit produces. This can cause the vinyl siding to deteriorate.

Note: Illustrations shown reflect "typical" installations with nominal dimensions and are for design and framing reference only. Actual installations may vary due to individual design preferences. However, always maintain minimum clearances to combustible materials and do not violate any specific installation requirements.

These fireplaces have been tested and listed by OMNI-Test Laboratories, Inc. (Report No. 116-F-37-2) to U.L. 127 (USA) and U.L.C. S610 (Canada). These units are intended for indoor and outdoor installations as specified in this manual.

For installations in Canada, the chimney clearance to combustibles must be 2 inches and the Cold Climate Kit must be installed.

! WARNING

Do not pack or fill required air spaces with insulation or other material. No material is allowed in these areas.

! AVERTISSEMENT

Ne remplissez pas les espaces libres d'une matière isolante ou de tout autre type de matériel. Aucun matériel n'est permis dans ces espaces vides.

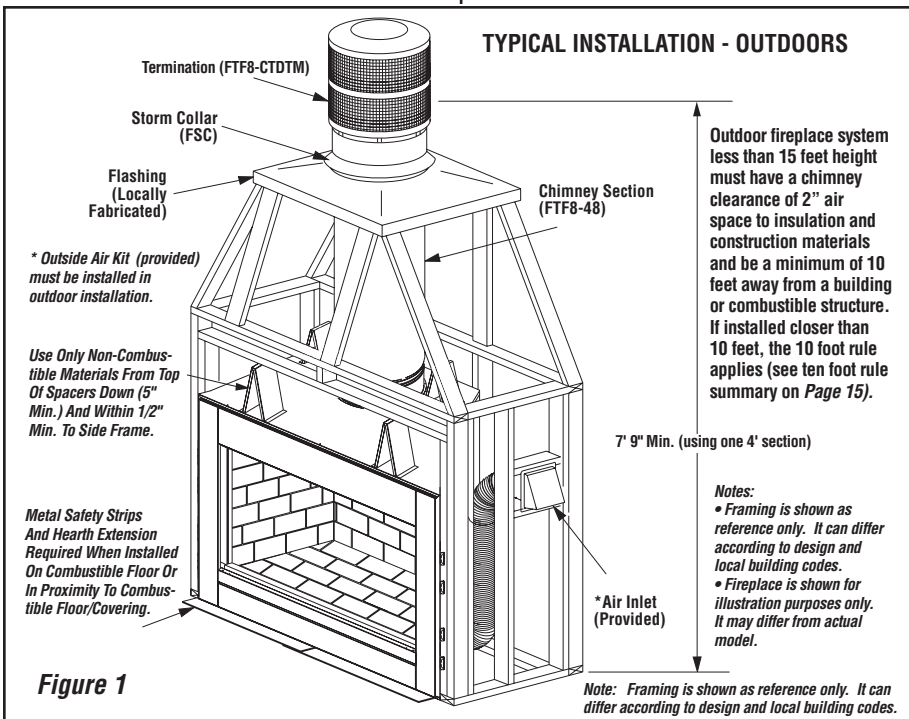

NOTE: DIAGRAMS & ILLUSTRATIONS ARE NOT TO SCALE.

! WARNING

If insulation is used, the fireplace must not be placed directly against it. Insulation or vapor barriers, if used, must first be covered with gypsum board, plywood, particle board or other material to assure insulation and vapor barriers remain in place.

! AVERTISSEMENT

Si un isolant est utilisé, il ne doit pas venir en contact avec le foyer. L'isolant ou le coupe vapeurs, si utilisée, doit d'abord être couvert d'un panneau de gypse, contreplaqué, panneau de particules ou d'un autre matériel pour s'assurer que l'isolant et le coupe vapeurs demeurent en place.

These fireplace systems are designed for installation in accordance with the National Fire Protection Standard for chimneys, fireplaces and solid fuel burning appliances; NFPA 211-latest edition and in accordance with codes such as the BOCA Basic/National Codes, the Standard Mechanical Code and the Uniform Building Codes.

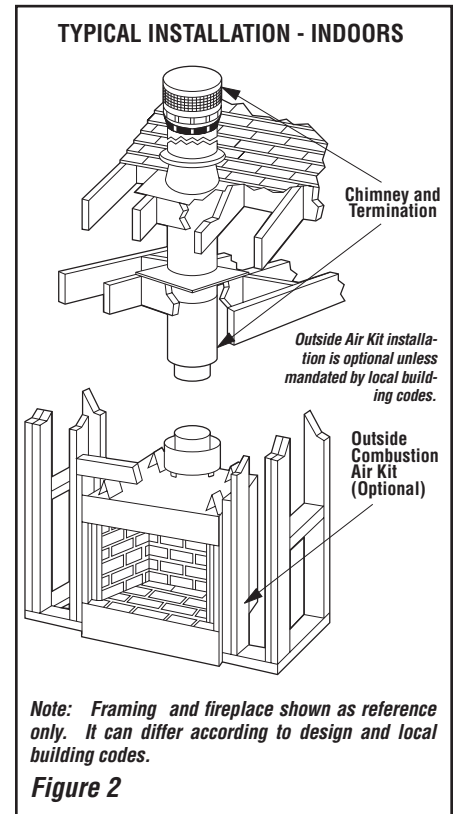

! WARNING

Failure to use manufacture provided parts, variations in techniques and construction materials or practices other than those described in this manual may create a fire hazard and void the limited warranty.

! AVERTISSEMENT

L'échec d'utiliser la fabrication les parties fournies, les variations dans les techniques et le matériel de construction ou les pratiques autre que ceux-là ont décrit dans ce manuel peut créer un risque d'incendie et un vide la garantie limitée.

When complete these fireplace systems consists of five basic "sub-systems":

1. The Fireplace
2. The Chimney and Termination
3. The Optional Glass Doors
4. The Optional Outside Air Kits
5. The Optional Weather Cover (for outdoor installations)

CLEARANCES AND HEIGHT REQUIREMENTS

The fireplace may be placed on or near normal construction materials*. The outside air kit, firestop spacer and roof flashing (not chase flashings) may be placed directly on or against normal construction materials. **

A combustible mantel may be installed 12" above the opening of the fireplace as per NFPA 211-latest edition. In Canada, the minimum is 18" above the fireplace opening.

** In the USA, the chimney and fireplace outer wrapper require a minimum 1" air space to insulation and construction materials.*

** Outdoor installations less than 15' height require chimney clearance of 2" air space to insulation and construction materials.*

** In Canada, the chimney and fireplace outer wrapper require a minimum 2" air space to insulation and construction materials.*

** Construction Materials:

- Framing Materials • Paneling
- Particle Board • Flooring
- Dry Wall • Plywood
- Noncombustible Insulating Materials
- Etc.

INDOOR INSTALLATIONS - The minimum installed height of the completed fireplace system for is 15' 0". The maximum height is 60' 0" (see **Table 1**).

OUTDOOR INSTALLATIONS - The minimum installed height of the completed fireplace system is 7' 9". The maximum height is 60" (see **Table 2**).

Outdoor installations less than 15' height require chimney clearance of 2" air space to insulation and construction materials.

The fireplace and chimney system must be enclosed when installed in or passing through a living area where combustibles or people may come in contact with it. This is important to prevent possible personal injury or fire hazard.

For questions, please call your distributor or the manufacturer. Special restrictions apply to the front and facing of the fireplace and nearby walls (See **Pages 20, 21 & 22**).

CHIMNEY SYSTEM

These fireplaces are designed and code listed for use with Security Chimneys FTF8 chimney System only. Always use Security Chimneys FTF8 chimney components with these fireplaces. Do not modify or alter these components as this may cause a potential serious hazard and void the Warranty.

Chimney Height - Indoor Installations

The total height of your completed fireplace system from the surface the fireplace rests on to the chimney top must not exceed 60' and must also meet minimum height requirements. Refer to the minimum system height chart (see **Table 1**).

Chimney Height - Outdoor Installations

The total height of your completed fireplace system from the surface the fireplace rests on to the chimney top must not exceed 60' and must also meet minimum height requirements. Refer to the minimum system height chart (see **Table 2**).

INDOOR INSTALLATIONS Minimum System Height Security's FTF8 Pipe	
Vertical Installation	15' 0"
One Offsets	15' 0"
Two Offsets	25' 0"
Table 1	

OUTDOOR INSTALLATIONS Minimum System Height Security's FTF8 Pipe	
Vertical Installation	7' 9" ❖
One Offsets	15' 0"
Two Offsets	25' 0"
Table 2 - See following Notes	

❖ Notes (Table 2)

- Outdoor fireplace system less than 15 feet height must have a chimney clearance of 2" air space to insulation and construction materials and be a minimum of 10 feet away from a building or combustible structure. The 10 foot rule applies on all cases (see ten foot rule summary on **Page 15**).
- The system height may be reduced to a single length of FTF8-48 pipe and termination with the FTF8-CTDTM for a minimum height on a complete system of 7' 9". The fireplace must be installed as a Freestanding system and located a minimum of 10' away from any building or structure (refer to **Figure 1**).
- The minimum height will vary when using other Firecraft or Lennox Terminations.

Chase Enclosure

A chase is a vertical box-like structure constructed to surround the fireplace and chimney. Refer to **Figure 4** for a typical chase configuration. As with all chimney installations, avoid overhead obstructions such as trees, power lines, etc. A chase should be constructed and insulated just like any outside wall. In a cold climate, we recommend the base of the chase should also be insulated between the solid continuous floor beneath the fireplace and the chase bottom. Chase insulation in a cold climate installation is not required for safety.

Note: Do not insulate the chase cavity with blown or fill type insulation materials.

Note: Local codes may not require firestopping at the ceiling levels for outside chase installations. However, it is recommended for safety and the reduction of heat loss.

ASSEMBLY OUTLINE Before You Start

Check your inventory list to be sure you have all the necessary parts supplied in good usable condition. Check also for any concealed damage.

Check the operation of the damper. The damper is controlled through the use of a control lever located within the firebox opening at the top center in front of the firebox lintel (**Figure 3**). The control lever snaps into place at either extreme of its range of motion. When locked in position all the way to the right, the damper is open. When locked in position all the way to the left, the damper is closed.

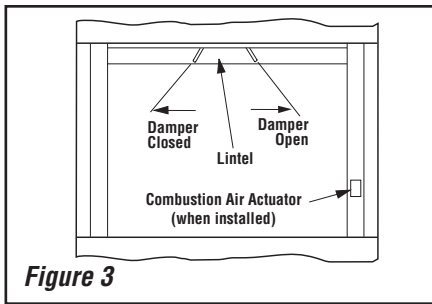

Figure 3

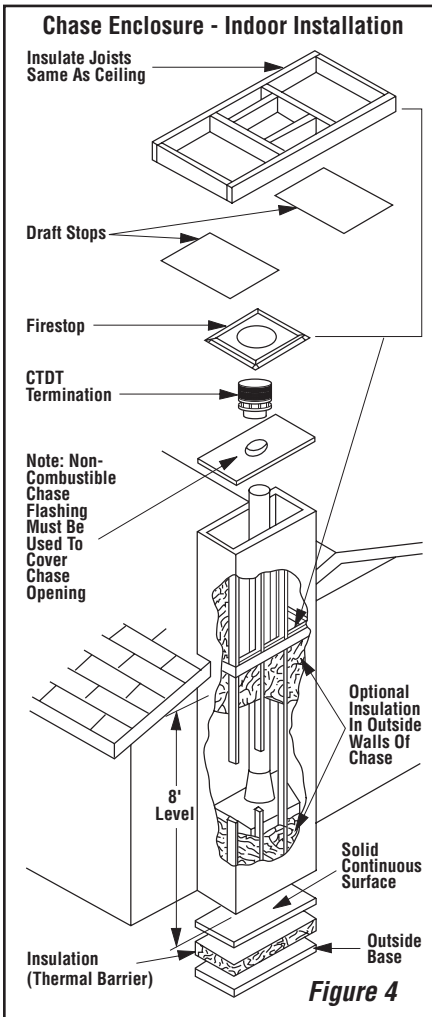

Figure 4

LOCATION OF FIREPLACE

Carefully select the proper location for heat circulation, aesthetics, chimney obstructions, air inlet location and clearance to side wall(s). With proper pre-planning, a slight adjustment of a few inches can save considerable time and expense later during construction and assembly. See **Figures 5 & 6** for examples.

When locating the fireplace, consideration must be given to combustibles and final finishing. See **Figure 5** and confine the final location of combustible finish materials to the "Safe Zone."

DO NOT permanently place furniture or other items such as decorative pillows within 60" of the fireplace front face.

Indoor Locations - Carefully consider the position of the fireplace opening with respect to the location of adjacent or nearby stairwells, bath or kitchen exhaust fans and/or return air registers for forced air furnaces/air conditioners that could cause a smoking fireplace condition if the house is tightly insulated.

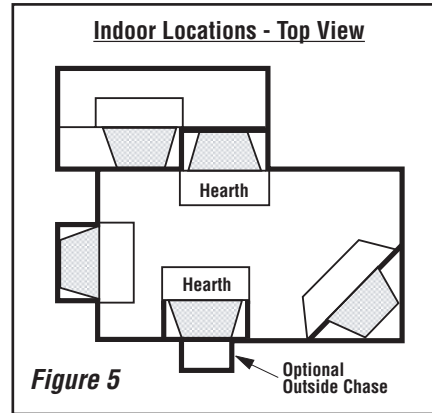

Figure 5

CAUTION

To ensure that the outside air kit remains open for an outdoor installation, this fireplace should not have a combustion air gate control installed (OAKG-OD). If this unit is installed indoors, you must install the outside combustion air cover provided or an optional outside air kit gate (OAKG-OD) before the fireplace is framed in place.

ATTENTION

Assurer que les restes extérieurs de kit d'air ouverts pour une installation extérieure, cette cheminée n'ont pas une commande de porte d'air de combustion a installé (OAKG-OD). Si cette unité est installée à l'intérieur, vous devez installer la couverture extérieure d'air de combustion fournie ou une porte extérieure facultative de kit d'air (OAKG-OD) avant que la cheminée soit encadrée en place.

Outdoor Locations - Carefully consider the position of the fireplace opening with respect to the location of adjacent or nearby stairwells, doors, windows, walk ways and over hanging trees, patios and wires.

When choosing a location, care must be taken to avoid places where flooding or running water may be a problem.

DO NOT place furniture or other items such as plants or decorative objects within 60" of the fireplace front face.

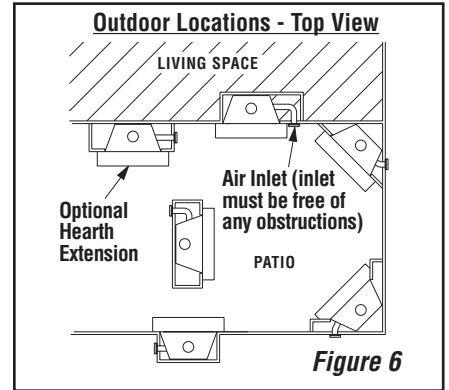

Figure 6

Restrictions for Outdoor installations:

- Outside Air Kit must be installed and fully open on the outdoor installation. On the indoor installation is optional unless mandated by local building codes.
- Minimum chimney height for the outdoor installation is 7' 9" (one 4 foot pipe section).
- Minimum 2" chimney clearance is required when system height is less than 15'.
- Only non-combustible materials are allowed on the front face (Front Fireplace Frame) and around the perimeter within 5" (full length of top spacers) on the top and 1/2" on the sides (see **Figures 1, 51 & 52**).

Combustible materials may project beyond the sides of the fireplace opening as long as they are kept within the shaded areas illustrated in **Figure 7**.

CLEARANCES

Minimum clearance to combustibles for the appliance is as follows: sides and back - 1" (25 mm), floor - 0" (0 mm), adjacent wall - 12" (305 mm), ceiling - 37 1/2" (953 mm).

Note: Clearance at the nailing tab is 0" (0mm) (see **Figure 25**).

Note: Adjacent wall considerations are for an adjacent wall on only a single side. Walls should not be placed at minimum distance at both sides of the fireplace.

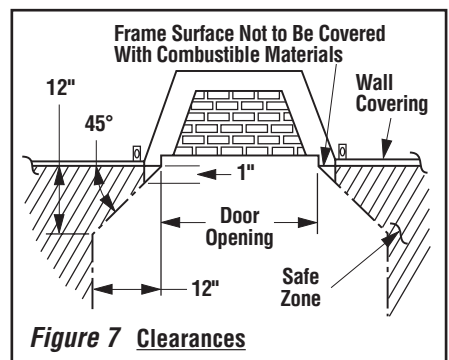

Figure 7 Clearances

ASSEMBLY STEPS

Note: The following steps represent the normal sequence of installation. Each installation is unique, however, and might require a different sequence.

1. Position firebox prior to framing or into prepared framing.
2. (Outdoor Installations) Waterproof the fireplace. See *Waterproofing The Fireplace* on **Page 6**.
3. Install the chimney system.
4. Install an outside air cover or an airgate kit, if fireplace is being installed indoors (optional accessory, see **Page 23** for ordering information). **The Airgate kit is required on all INDOOR installations when an outside air kit is installed. The Airgate Kit is NOT approved for use on outdoor installations.**
5. Install outside air kit (provided). This kit is required on ALL outdoor installations (optional for indoor installations).
6. Plumb gas line if a decorative gas appliance will be used. (Gas connections should only be performed by an experienced, licensed/certified tradesman).
7. Complete the installation, finish wall material, surround and hearth extension to your individual taste.
8. Assemble and attach optional glass door assembly.

Study the illustration of the installation, **Figures 1 & 2**, to get a general idea of each element of your fireplace system.

PRE-INSTALLATION NOTES

The fireplace may be installed directly on a combustible floor or raised on a platform of an appropriate height. Do not place fireplace on carpeting, vinyl or other soft floor coverings. It may, however, be placed on flat wood, plywood, particle board or other hard surfaces. Be sure fireplace rests on a solid continuous floor or platform with appropriate framing for support (and for indoor installation ensure that no cold air can enter the room from under the fireplace).

The fireplace may be positioned and then the framing built around it, or the framing may be constructed and the fireplace positioned into the opening.

Usually, no special floor support is needed for the fireplace, however, to be certain:

1. Estimate the total weight of the fireplace system including chimney and surround materials such as brick, stone, etc., to be installed. Shipping weight for the fireplace may be found on **Page 9** (see *Product Reference Information*).
2. Measure the square footage of the floor space to be occupied by the system, surrounds and hearth extensions.
3. Note the floor construction, i.e. 2 x 6's, 2 x 8's or 2 x 10's, single or double joists, type and thickness of floor boards.
4. Use this information and consult your local building code to determine if you need additional support.

If you plan to raise the fireplace and hearth extension, build the platform assembly then position fireplace and hearth extension on top. Secure the platform to the floor to prevent possible shifting.

WATERPROOFING THE FIREPLACE Outdoor Installations

Although the fireplace is designed to drain to the front most of the water from rain and other sources that may enter the hearth area, condensation and unusual conditions may cause water to collect inside the fireplace bottom.

To prevent water collection, the builder must provide a means to drain water from under the fireplace by building or installing a water collector of the builder's choice before positioning the fireplace on its location.

INDOOR INSTALLATIONS ONLY

Outside Air Cover

If the optional outside air kit is not required in an indoor installation, you must install the outside air cover to close the opening for the

⚠ WARNING

Indoor Installations - If the optional outside air kit is not required, the outside air cover must be installed for safe fireplace operation.

⚠ AVERTISSEMENT

Installations d'intérieur - si le kit extérieur facultatif d'air n'est pas exigé, la couverture extérieure d'air est exigent pour l'opération sûre de cheminée.

The *Outside Air Cover* is included in the Installation Instructions package provided with this fireplace. Follow the steps below:

- a. Remove the Outside air collar located on the side of the fireplace. Do not discard the screws (see **Figure 8, Photos A & B**).
- b. With the screws previously removed, install the cover provided with the installation instructions kit (see **Figure 8, Photo C**).

NOTE: DIAGRAMS & ILLUSTRATIONS ARE NOT TO SCALE.

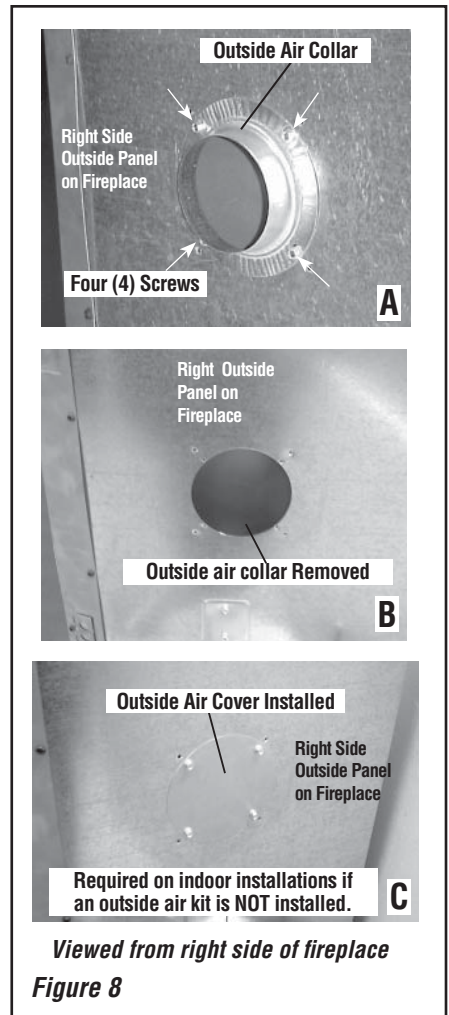

Outside Air Kit Gate Installation (optional kit) Indoor Installations Only

The installation of the Air Gate (shutter) is required on all indoor installations to prevent cold air infiltration when an outside air kit, OAK-OD (duct & hood), is installed. The Outside Air Kit Gate, OAKG-OD (air gate & arm), must be purchased and installed before the fireplace is installed.

1. Remove the Outside Air Collar located on the right hand side of the fireplace (retain the screws). See **Figure 8, Photos A & B**.
2. Install the Outside Air Kit Gate (OAKG-OD) per the instructions in the kit and the following instructions using the screws provided.
 - a. Assemble the Air Gate Arm to the Air Gate as shown in **Figure 9**.
 - b. Take the Air Gate Assembly and feed the arm through the round opening (see **Figure 10**) and then through the side frame opening in the front as shown in **Figure 11**.

Assemble the Air Gate and Arm as shown.

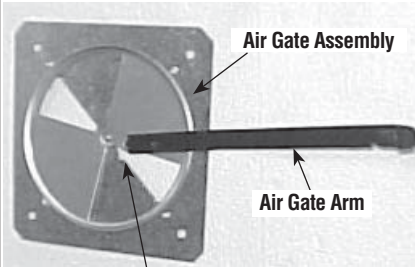
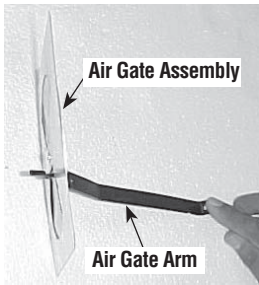

When assembled onto appliance, the notch here must be positioned as shown

Figure 9- Outside Air Kit Gate

IMPORTANT! IF THE AIR GATE IS INSTALLED UPSIDE DOWN (WITH THE NOTCH POSITIONED ON THE UPPER HALF) IT WILL NOT WORK PROPERLY. REFER TO FIGURE 9.

c. Ensure the air gate arm remains attached to the air gate, secure the Air Gate to the fireplace, with the screws provided, as shown in **Figures 12 & 13**.

d. Verify the mechanism is working by pulling to open and pushing to close.

3. Install the Outside Air Collar with the screws removed earlier (see **Figure 14**).

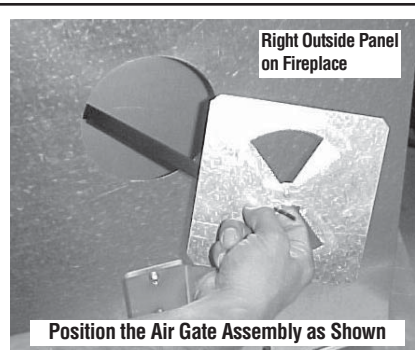

Figure 10 - Air Gate Assembly to Fireplace

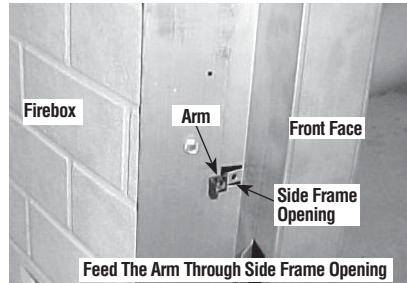
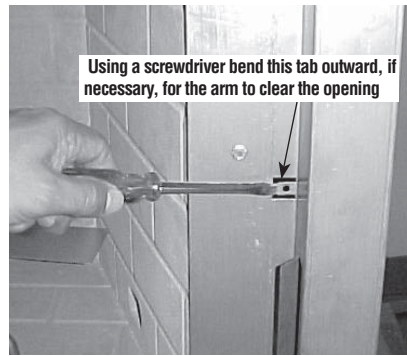

Figure 11 - Air Gate Arm in Front



Figure 12 - Position Air Gate



Figure 13 - Install Screws

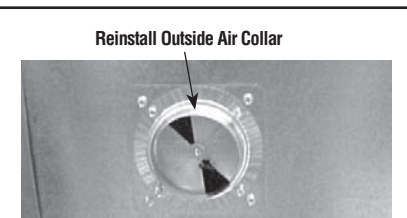

Figure 14 - Reinstall Connector

4. Install an Outside Air Kit (with duct and hood) per the instructions provided with kit.

a. If the outside air kit is NOT installed, you must install the Outside Air Cover provided with the instructions kit.

b. If an outside air kit IS installed, the Outside Air Kit Gate must be installed (see **Page 23** of ordering information).

The Outside Air Kit Gates are required on all indoor installations only. They are not approved for use on outdoor installations.

Air Gate Operation Instructions

Install the Air Gate Kit per the instructions provided with kit (see **Page 23** for ordering information).

Air Gate Kit (purchased separately)

Combustion Air Actuator

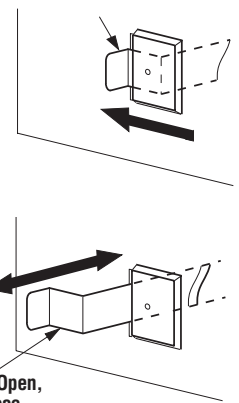

Pull Forward to Open, Push Back to Close

Figure 15

To operate, push the end of the actuator arm to the left as shown in **Figure 15**, until it "pops" free of its "locked" position. Pull the actuator forward to open the combustion air door, and push it back to close. To "lock" the combustion air door closed, ensure the actuator is pushed all the way back then push the end of the actuator to the right until the step in the actuator moves behind the appliance front face within the slotted opening.

Operate the actuator through several cycles including the "lock" position. Ensuring proper operation and freedom of movement. Return the actuator arm to the locked position.

Outside Air Kit Installation (provided)

These appliances are equipped with a combustion air inlet collar so that it is possible to duct combustion air from the outdoors to the firebox. To accomplish an outside air hook-up, use only the *Outside Air Kit* provided with these appliances. These kits come complete with all components necessary in completing a combustion air vent system.

Indoor Installations - An *Air Gate Kit* must be installed prior to the installation of the *Outside Air Kit* (purchased separately - see **Page 23** for ordering information).

Outdoor Installations - Units installed outdoors are required to have the *Outside Air Kit* (provided) installed without the *Air Gate Kit*. The optional *Air Gate Kit* is not approved on outdoor installations.

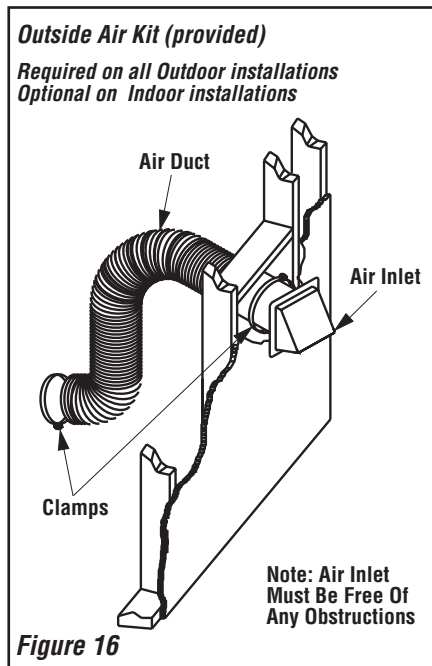

Install as follows:

Connect the 4" (102 mm) Class 0 air duct provided, to the collar on the fireplace with the clamps provided in the kit's hardware package (**Figure 16**).

Route the Class 0 metallic air duct out the back wall or side wall, up through the ceiling or floor joists to an outside wall. **The air duct's inlet should be located above any anticipated snow level.** Check local building codes for any restrictions. We recommend that the inlet be at least 4 feet above grade level.

Note: Air inlet ducts must not terminate in attic space.

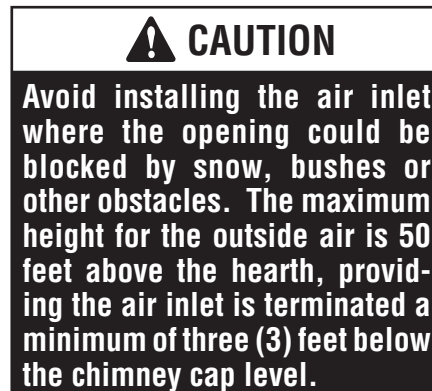

Note: Secure the duct hood to a vertical post with the inlet positioned downward. Ensure that nothing blocks the hood opening. This duct must never terminate higher than 3 feet below the fireplace termination (**Figure 17**).

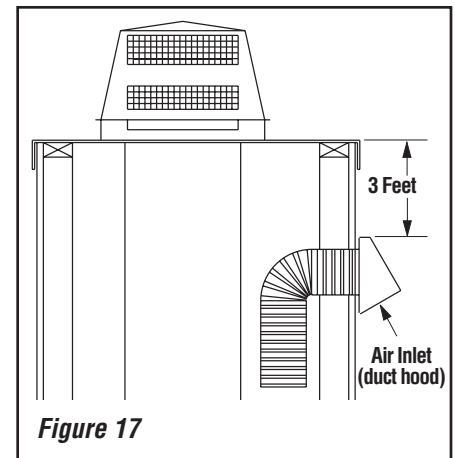

Duct Hole Framing:

Cut or frame a hole through the outside of the enclosure for the installation of the duct inlet hood. A 5" (127 mm) diameter hole is required. Feed the loose end of the flexible duct through the hole cut for the inlet hood and attach to the collar on the inlet hood using two (2) screws. Insert the hood into the opening. Secure in place with nails driven through the holes in hood flange. Seal with noncombustible waterproof silicon type caulking. If additional duct is needed, use Class 0 metallic air duct (refer to **Figure 16**).

FIREPLACE SPECIFICATIONS - MODEL MP-420D

Product Reference Information			
Cat. No.	Model	Ship. Weight	Ship. Volume
H1934	MP-420D	188 lb.	24 cu. ft.

Framing Dimensions		
A	46-1/2"	1181 mm
B ₁	43-1/2"	1105 mm
B ₂	60-1/2"	1537 mm
C	33"	828 mm
D	17-1/2"	445 mm
E	76-1/4"	1937 mm
F	38-1/8"	968 mm
G	21-5/8"	549 mm
H	20-5/8"	524 mm
J	53-7/8"	1362 mm
K	8"	203 mm

Notes

Due to Lennox' ongoing commitment to quality, all specifications, ratings and dimensions are subject to change without notice.

All framing dimensions calculated for 1/2" dry wall at the fireplace face. If sheathing the chase or finishing with other thickness materials, calculations will need to be made.

See Page 10 for Ceiling and Roof Framing Dimensions

Diagrams & Illustrations Not to Scale

Tested & Listed By  Beaverton Oregon USA
 OMNI-Test Laboratories, Inc.
 OTL Report No. 116-F-37-2

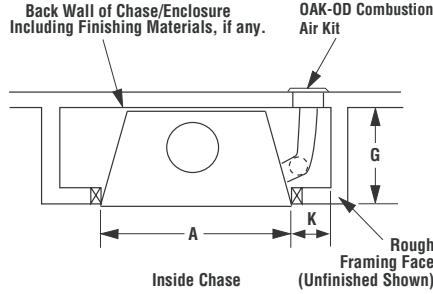

Outside Chase - Indoor Installations

****Note:** When Framing With 6" Studs Header Must Be 17" (432mm) Higher. Use Security Chimney's OR15 Offset/Return Elbow To Recess The Chimney Back 2 1/2" (64mm). Flat Frame Down To A False Header At (B₁). Maintain Required Clearance To Chimney At All Times.

* 1" Air Space to insulation and construction materials on the back and sides.

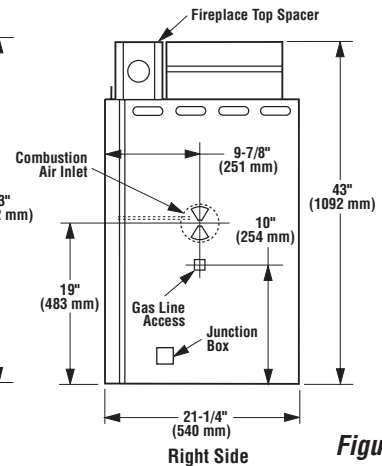
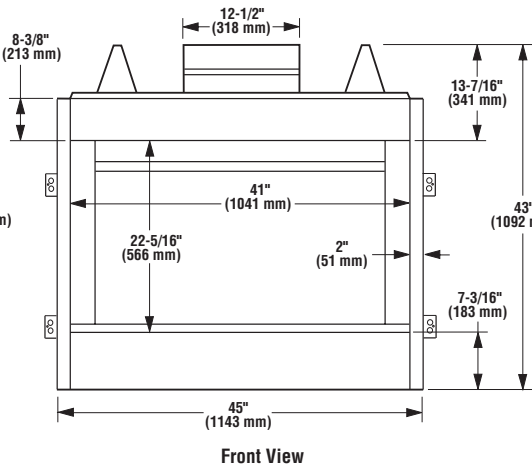
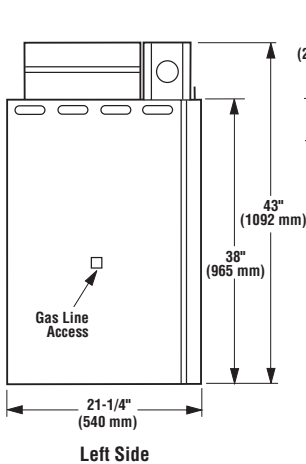
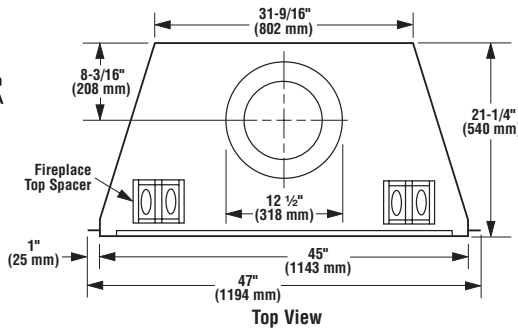
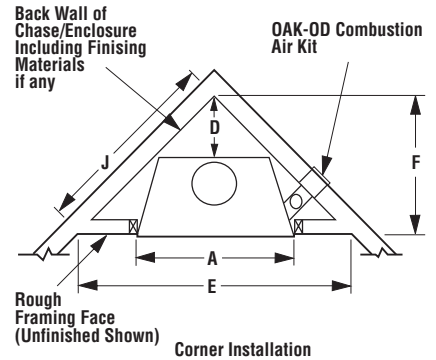
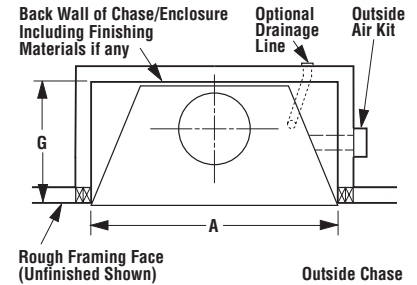
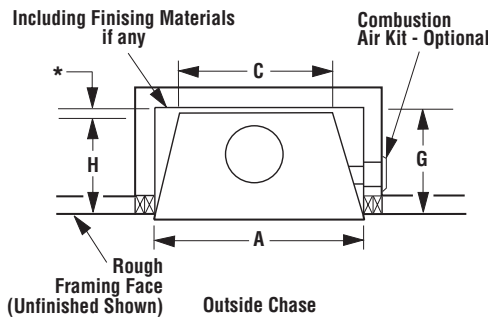
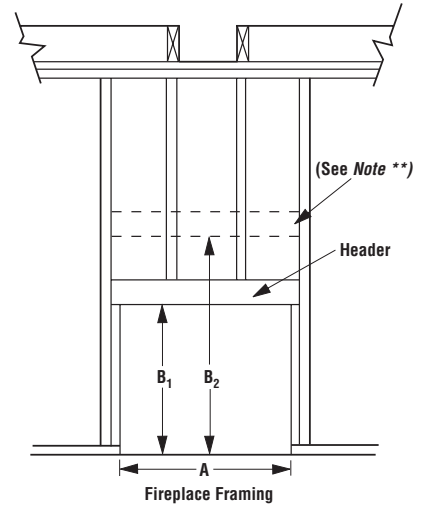
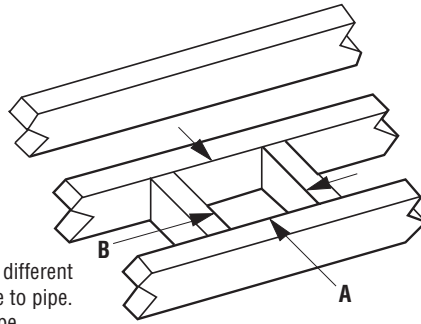

Figure 18

Framing Ceiling

Frame the opening for the ceiling as specified here.



Note: Framing Dimensions in Canada & USA are different because installations in USA require 1" Clearance to pipe. Installations in Canada require 2" Clearance to pipe.

Ceiling Framing

Framing Dimensions for Ceiling Inches (millimeters)		
Flue Type	A	B
FTF8 Vertical (USA)	14 1/2" (368 mm)	14 1/2" (368 mm)
FTF8 Vertical at 2" (Canada)	16 1/2" (419 mm)	16 1/2" (419 mm)
FTF8 Offset 30° (USA)	14 1/2" (368 mm)	25" (635 mm)
FTF8 Offset 30° at 2" (Canada)	16 1/2" (419 mm)	27" (686 mm)

Figure 19

Framing Roof

Frame the opening for the roof as specified here.

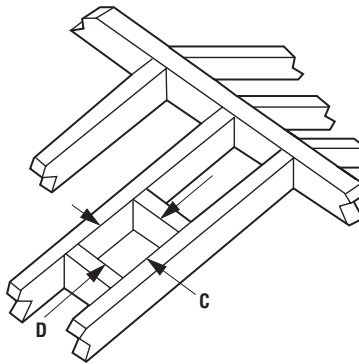

Note: Framing Dimensions in Canada & USA are different because installations in USA require 1" Clearance to pipe. Installations in Canada require 2" Clearance to pipe.

Roof Framing

Framing Dimensions for Roof Inches (millimeters)				
Pitch	FTF8 at 1" (USA)		FTF8 at 2" (Canada)	
	C	D*	C	D*
0/12	14 1/2" (368 mm)	14 1/2" (368 mm)	16 1/2" (419 mm)	16 1/2" (419 mm)
6/12	14 1/2" (368 mm)	17" (442 mm)	16 1/2" (419 mm)	19" (483 mm)
12/12	14 1/2" (368 mm)	21 1/2" (546 mm)	16 1/2" (419 mm)	23 1/2" (579 mm)

* Perpendicular to roof ridge

Figure 20

INSTALLING THE FIREPLACE

Step 1. Slide the fireplace into prepared framing or position fireplace in its final position and frame later.

The fireplace may not be recessed into a combustible floor. Maintain the floor to hearth clearance established by the fireplace lower front face.

Step 2. Insert the provided metal safety strips, beneath the fireplace as illustrated (Figures 21, 22 & 23). The safety strips should overlap 1/2 min. for continual coverage of the floor.

Note: Safety strips are not required when fireplace rests on a noncombustible surface.

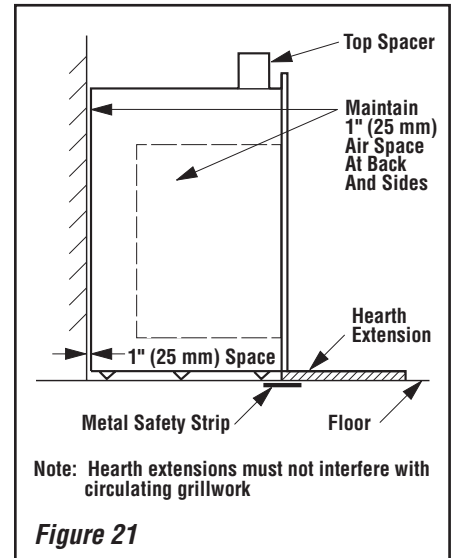

Figure 21

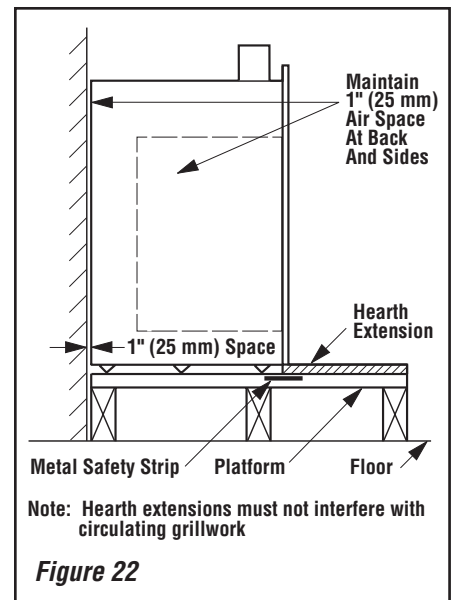

Figure 22

Note: Install the hearth extension only as illustrated (see **Figures 21 & 22**).

The safety strips should extend from front of the fireplace at least 1 1/2" and should extend to be at least flush with the sides. In the event a wooden support is used to elevate the fireplace above the floor, a "Z" type safety strip should be fabricated and used to protect the front surface of the wood support as well as the floor beneath the hearth extension (**Figures 23 & 24**). The safety strips should be tacked down to prevent possible movement.

Note: The "Z" type safety strip is not supplied.

Note: Safety strips are not required when fireplace rests on a noncombustible surface.

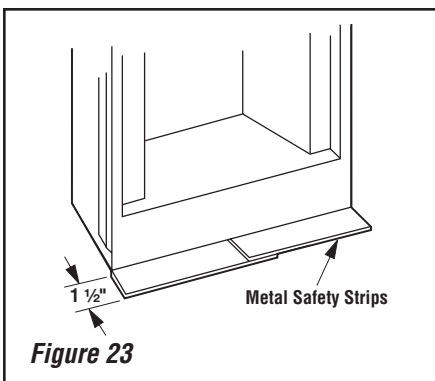

Figure 23

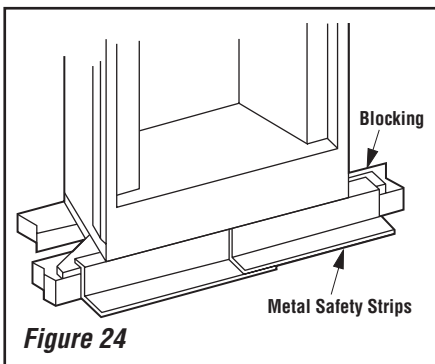

Figure 24

Step 3. Refer to fireplace drawings and specifications (see **Figures 18, 19 & 20**) for framing dimensions and details. Frame appliance enclosure as illustrated in **Figure 18**.

Note: The framed depth, 21 5/8" (549 mm) from a framed wall, must always be measured from a finished surface. If a wall covering such as drywall is to be attached to the rear wall, then the 21 5/8" (549 mm) must be measured from the drywall surface. It is important that this dimension be exact.

If the appliance is to be elevated above floor level, a solid continuous platform must be constructed.

The header may rest on the top metal spacers, but must not be notched to fit around them.

Consult all local codes.

⚠ WARNING

Under no circumstances can the fireplace top spacers (see **Figure 18) be removed or modified, nor may you notch the header to fit around or be installed lower than the spacers. The header may be in direct contact with the top spacers but may not be supported by them.**

⚠ AVERTISSEMENT

Sous aucune circonstance les espaceurs du dessus du foyer (voir le schéma 13) ne peuvent être retirées ou modifiées, vous ne pouvez pas entailler le colombage pour ajuster autour ou être installé plus bas que les espaceurs. Le colombage peut être en contact direct avec les espaceurs du dessus mais ne peut être soutenu par eux.

Step 4. The fireplace should be secured to the side framing members through the nailing tab at the top and bottom on each side of the fireplace front face. Use 8d nails (**Figure 25**).

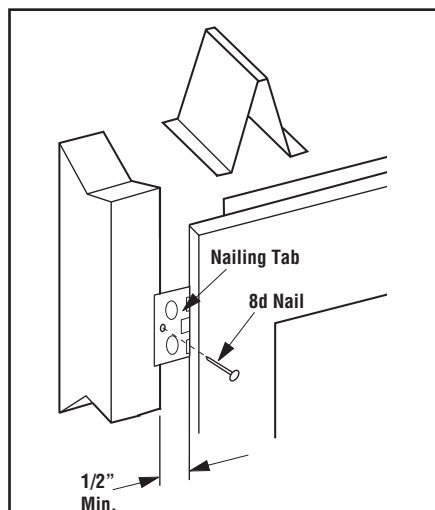

Note: The nailing tab and the area directly behind the nailing tab is exempt from the clearances described on **Page 5**. Maintain at least 1/2" clearance from the firebox wrapper to the framing at the closest point of contact, directly adjacent to the flange.

Figure 25

NOTE: DIAGRAMS & ILLUSTRATIONS ARE NOT TO SCALE.

For Canadian Installations - A Cold Climate Kit, FTF8-CCK3-LD, must be installed in all indoor installations. Installer must supply suitable length of 6" Diameter, class "0" metallic air duct.

Step 5. Attach the cold climate kit, around the chimney collar with the screws provided (see **Figure 26**).

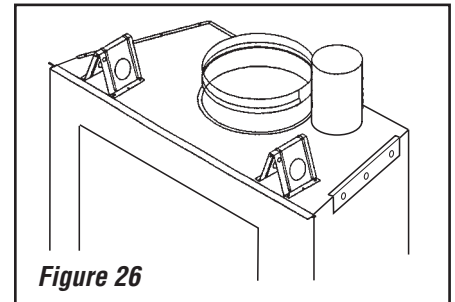

Figure 26

Cold Climate Kit Installation Instructions:

1. Connect the 6" (102 mm) Class 0 air duct provided by installer, to the duct collar on the fireplace and secure with two (2) screws from the kit's hardware package.
2. Route the Class 0 air duct out the back or side wall, up through the ceiling or floor joists to an outside wall. The air inlet hood should be located above snow level or above any anticipated snow level, (**Figure 19**).

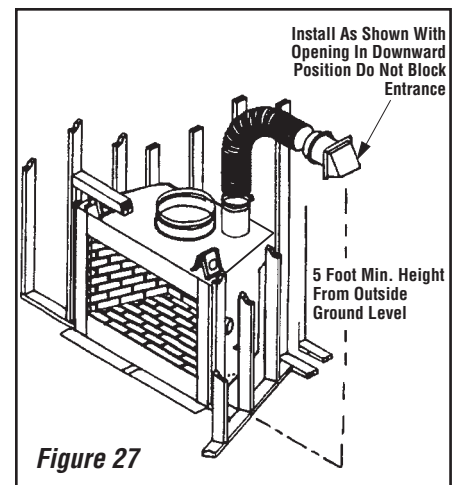

Figure 27

Note: If the fireplace is installed against an inside wall, the class 0 air duct may be extended into a ventilated attic space at least 18" (475mm) above the attic floor. Secure the air inlet hood to a vertical post with the inlet positioned downward. Ensure that nothing blocks the hood opening. This hood must never terminate higher than three (3) feet below the termination.

3. Cut or frame a hole through the outside wall for the installation of the air inlet hood. A 6-1/2" diameter hole is required. Feed the loose end of the flexible duct through the hole and attach to the collar on the air inlet hood using two (2) screws from the kit's hardware package. Insert the hood into the opening. Secure the inlet hood in place with nails driven through the holes in the flange. Seal with noncombustible waterproof silicon type caulking.

Steps 6 - Install Air Gate Kit

(Required on All Indoor Installations. When an Outside Air Kit is installed, see assembly steps on Page 6).

Install the Air Gate Kit per the instructions provided with kit and on **Page 6** (see **Page 23** for ordering information).

Step 7. Outside Air Kit (provided)

(Required on All Outdoor Installations)

Install the Outside Air Kit per the instructions provided with kit and on **Page 7**.

Step 8. Route the Class 0 metallic air duct per the instructions on **Page 8**.

Step 9. Cut or frame a hole through the outside of the enclosure for the installation of the duct inlet hood per the instructions on **Page 8**.

INSTALLING THE CHIMNEY SYSTEM

Step 1. Before continuing, check the operation of the damper, as described on **Page 5**, (refer to **Figure 3**).

Step 2. Using standard construction framing techniques, construct opening for chimney route up through the ceiling(s) and roof or through an outside chase.

Framing must maintain adequate minimum air space clearance at all times.

CAUTION

Allow minimum 1" chimney air space to insulation and building materials throughout vertical or offset chimney installation.

ATTENTION

Permettez à minimum 1 pouce* espace aérien de cheminée à l'isolation, aux matériaux de construction et aux membres encadrants dans toute la verticale ou excentrez l'installation de cheminée.

A minimum 1" air space must be reserved for clearance to insulation and construction materials extending for any continuous length surrounding the chimney.

**Note: 2" air space to insulation and construction materials required in Outdoor Installations when system height is less than 15 feet (see Table 2, Page 4).*

In Canada, the chimney and outer wrapper require a minimum 2" air space to insulation and construction materials.

Reference **Figures 19 & 20** and charts Framing Dimensions for Ceiling and Roof, which specify minimum ceiling and roof dimensions.

In new construction, to determine chimney center line, use plumb line from roof or ceiling above fireplace to center of flue collar on fireplace.

For remodeling, plumb to center of flue collar from ceiling above, drive nail through ceiling from below to mark position, then mark and cut to passage from above ceiling (around nail) (see **Figure 28**). Then plumb from ceiling or roof level directly above hole which has just been completed.

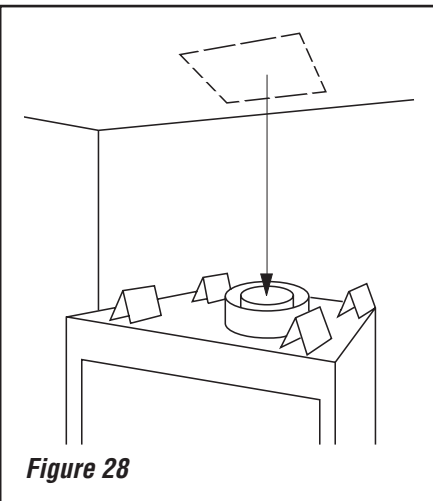

Figure 28

Step 3. Position appropriate firestop spacer at ceiling and nail temporarily with two (2) 8d nails. Use flat firestop spacer, Model F8FS, if chimney penetrates ceiling vertically. If chimney penetrates ceiling at 30° angle (offset chimney), use 30° firestop spacer, Model F8FS30. Use one nail on opposite sides to hold firestop spacer in position. Nail permanently, using at least two (2) more 8d nails, after chimney sections have been assembled through the firestop spacer and after any necessary adjustments have been made. Firestop spacer must be secured by at least four (4) 8d nails when completely installed.

Notes:

Indoor Installations: If there is a room above ceiling level, firestop spacer must be installed on the bottom side of the ceiling. If an attic is above ceiling level, firestop spacer must be installed on top side of ceiling joist (**Figures 29 & 30**).

Outdoor Installations: If patio installation requires that a chimney passes through a roof or room above, be sure to comply with all local building codes.

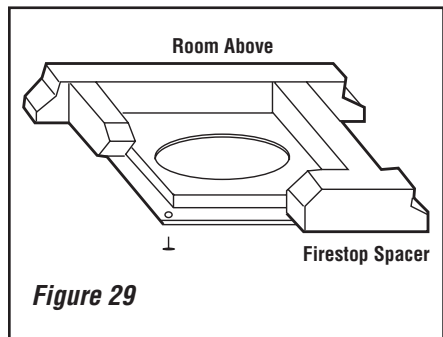

Figure 29

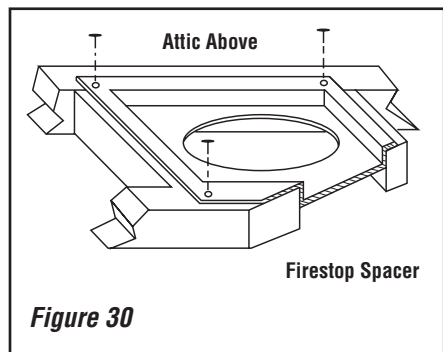
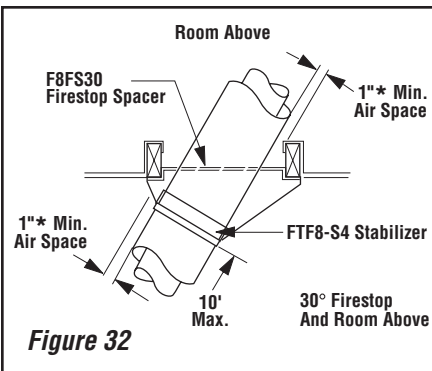
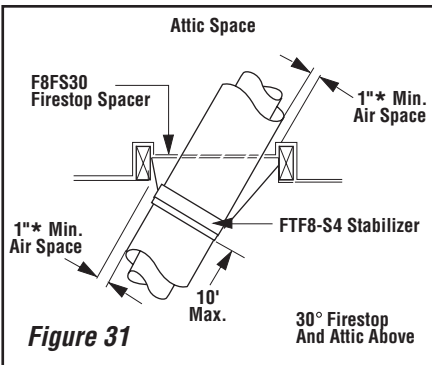

Figure 30

CHIMNEY 30° OFFSET THROUGH FLOOR OR CEILING

It may be necessary to assemble the chimney at 30° when passing through the floor or ceiling area. Use the F8FS30 firestop spacer as shown in **Figures 31 & 32**. Support the chimney at floor or ceiling penetration with a FTF8 stabilizer if distance of chimney below ceiling is 10' or more. Maintain 1" minimum air space to combustibles from chimney sections.



For Canada Only

When installing the chimney system through an open attic space, the attic shield assembly-firestop spacer must be used (**Figure 33**). This installation is required only for use in Canada.

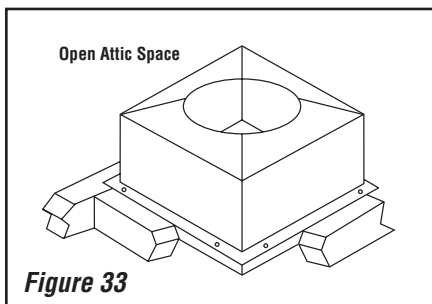

Note: For Canadian installations, all chimney installed outside the building must be constructed with galvalume (outer sections only). The appropriate model designations are located in the back of this manual.

Step 4. Note: Chimney sections are constructed with a unique locking tab design, which ensures an immediate, tight assembly between sections. Plan your chimney requirements carefully before assembly as chimney is difficult to disassemble after installation. If disassembled, the tabs might become damaged. Be certain tabs are properly formed to ensure locking tabs engage properly.

The Security Chimney's FTF8 chimney system is a two piece chimney, which snap together from the fireplace up. Start with the inner flue section with the lanced end up, snap lock it in to the matching collar on top of the fireplace. At all subsequent joints, the upper flue section fits into the preceding flue section. Each piece snaps together by means of locking tabs (9 locking tabs per joint). Check each piece by pulling up slightly from the top to ensure proper engagement before installing the next section. If the flue has been installed correctly, it will not separate when you test it. Also, the inner flue joint where each section is joined should be tight and flat without gaps (**Figure 34**).

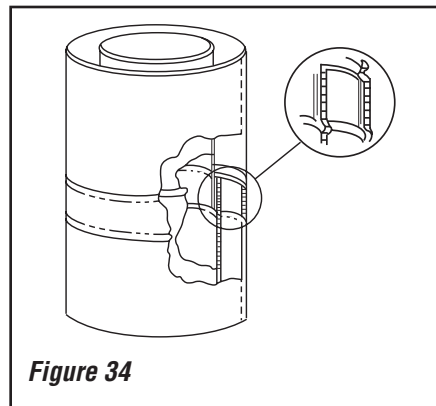

The outer chimney section installs the opposite-way; the lanced end goes down and each new section goes OVER the outside of the previous section installed (**Figure 35**).

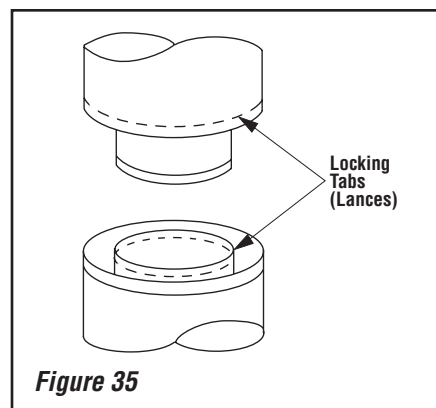

Note: Assemble one component of chimney at a time (inner section first, then outer section last) before proceeding with the next complete section.

Continue to assemble the chimney up through framed opening. Assemble just enough to penetrate the roof flashing openings (**Figure 36**). Always maintain 1" minimum air space to insulation and construction materials. Always check each chimney joint (inner and outer) to ensure proper engagement. Check vertical alignment of chimney so that it projects from the roof in true vertical position.

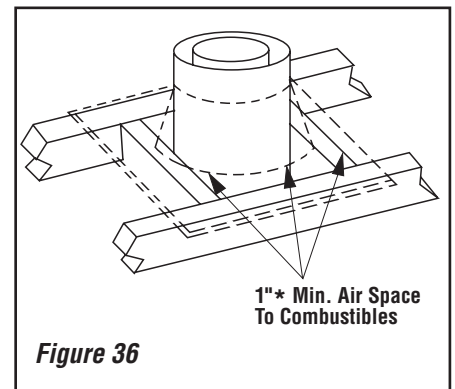

Security's chimney sections do not need to be screwed together. Additional reinforcement is not necessary except in certain offset conditions (refer to **Page 16, Figure 47**).

Step 5. The height of vertical chimney pipe supported only by the fireplace must not exceed 30'. Chimney heights above 30' must be supported by a Model FTF8-S4 stabilizer installed at 30' intervals.

Note: The Model FTF8-S4 adds 3" net effective height to the total chimney system.

Install the Model FTF8-S4 stabilizer by fitting inner section down into respective section of proceeding flue pipe and locking outer stabilizer section into place over the outer chimney pipe. Position for proper clearance through framed opening and nail straps securely (under tension in "shear") into place on framing. Use 8d nails. Attach successive lengths of chimney pipe directly to stabilizer using same techniques as described in **Step 4** (see **Figure 37**).

*Notes:

- 2" clearance to combustibles required in Canada.
- Outdoor installations less than 15' height require chimney clearance of 2" air space to insulation and construction materials.

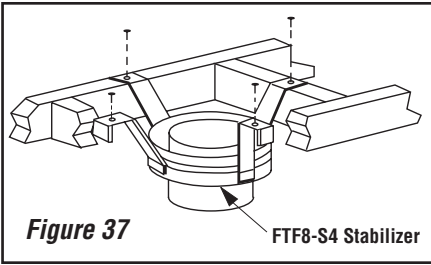

Figure 37 FTF8-S4 Stabilizer

Note: Do not apply excessive pressure to any subsequent chimney sections following the stabilizer when installing. Ensure each subsequent chimney section is securely attached by testing as noted in **Step 4**.

Step 6. Select the proper Security Chimneys roof flashing based on pitch of roof. Use chart below for selection:

Roof Pitch	Model
Flat to 6/12	F8F6
6/12 to 12/12	F8F12

Next, slide roof flashing over extended chimney section that previously has been installed above the roof opening in **Step 4**. FTF8 flashings require flashing spacers. Slide flashing all the way down until the flashing base rests flat on the roof (**Figure 38**). Again, check the vertical position of the chimney and the 1" minimum air space to insulation and construction materials.

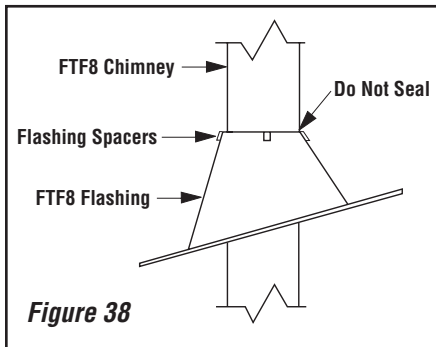

Figure 38

Note: Do not caulk or seal the ventilating openings or seal the flashing at the chimney.

Step 7. Secure flashing by nailing along the perimeter into roof using 8d nails. If shingled roof, slide upper end and sides of roof flashing under shingles (trim if necessary), seal the top and both sides of the flashing to the roof with roof caulking. Cover nail heads with roof caulking (**Figure 39**).

*** Notes**

- 2" clearance to insulation and construction materials required in Canada.
- Outdoor installations less than 15' height require chimney clearance of 2" air space to insulation and construction materials.

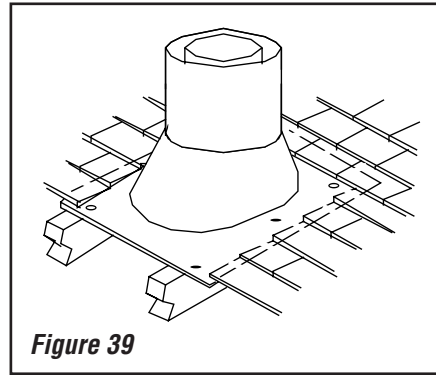

Figure 39

Step 8. The standard Security FTF8 roof flashing assemblies include a storm collar. Slide the storm collar over outer chimney, rest on flashing spacers and align with top surface of flashing. Insert tab in slot, pull tight and bend tab back over slot. Seal storm collar to outer chimney with roof caulking or mastic around entire circumference of pipe. Also add extra roof caulking to the tab/slot area to seal completely against water penetration (**Figure 40**). Check all joints very carefully to ensure no water intrusion can take place.

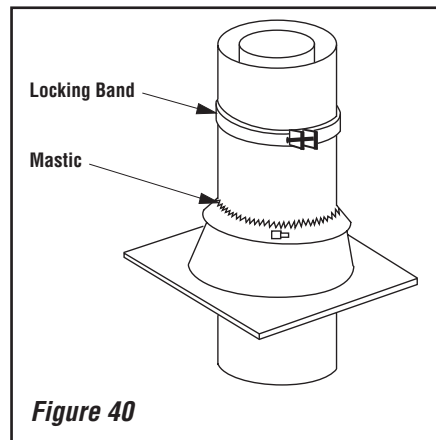

Figure 40

Step 9. Security Chimneys locking bands, Model FLB, may be required if the chimney extends too high above the roof flashing. As a general rule, if the chimney extends more than 6' above the roof flashing, the use of locking bands is advisable to strengthen the chimney assembly. Align the locking band at the chimney joint. Locking bands wrap around pipe joints equally covering the joints of both pipe sections. Use the nut provided and TIGHTEN snugly. Do not overtighten as this might damage the chimney section (refer to **Figure 40**).

Note: If chimney extends more than 8' above roof surface, guy wires are also recommended. Use three (3) guy wires, attach to locking band assembly, extend and secure to roof in a triangular pattern (see **Figure 41**). Guy wires are not supplied by the manufacturer.

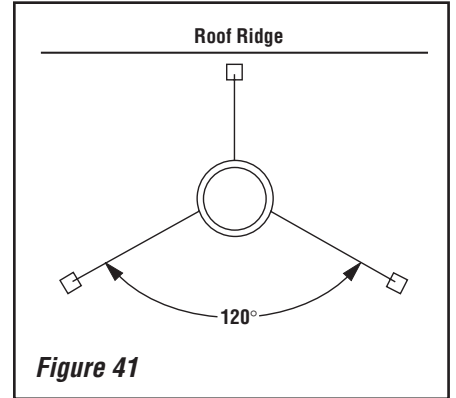

Figure 41

Step 10. Using a FTF8-CTD or FTF8-CTDT Round Termination (indoor fireplace installations only):

1. Hold the FTF8-CTD (or CTDP) over top of last chimney section (**Figure 42**).
2. Center inner slip section in inner flue pipe-slip down.

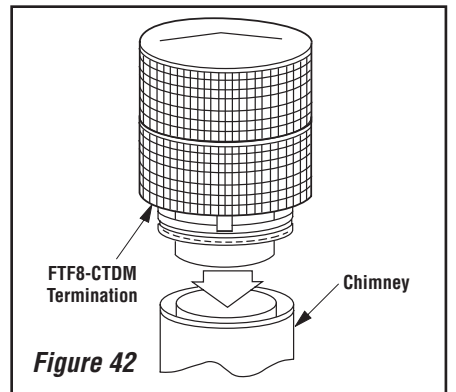

Figure 42

3. Center outer locking section over outer flue pipe. Push down until locking tabs are firmly engaged.
4. Pull up slightly on CTD to ensure locking joint has firmly engaged.

Using a FTF8-CTDTM Chase Termination:

Refer to specific installation instructions (750,205M) included with the FTF8-CTDTM chase termination for clearance and installation details.

Using a FTF8-CT1 or FTF8-CT1P Chase Termination:

Refer to specific installation instructions (750,015M) included with FTF8-CT1 chase terminations for clearance and installation details.

Using a FTF8-CT2 Chase Termination:

Refer to specific installation instructions (750,016M) included with FTF8-CT2 chase terminations for clearance and installation details.

Using a FTF8-CTT Chase Termination:

Refer to specific installation instructions (750,077M) included with FTF8-CTT chase terminations for clearance and installation details.

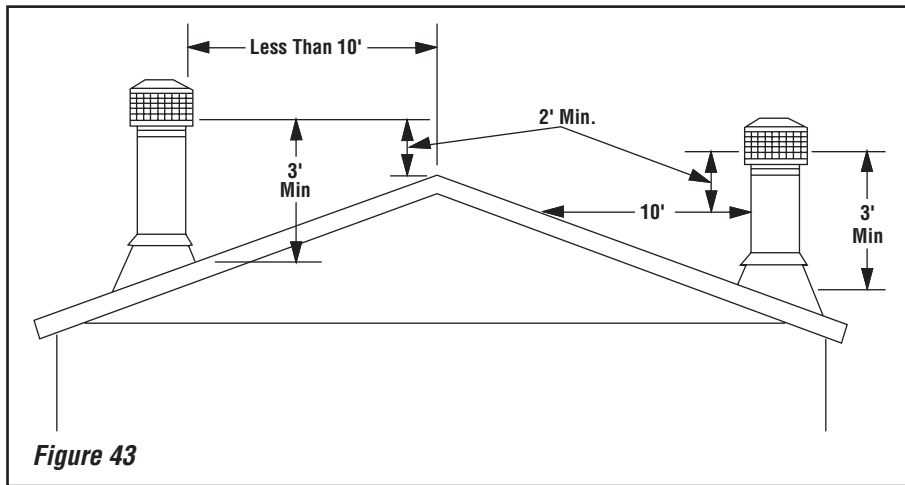

Figure 43

Note: It is recommended that all exterior exposed metal fireplace components; such as terminations, flashings, storm collars and/or flue be painted with a premium quality, high temperature, rust preventative paint designed for metal. This is especially important when installations are made in abnormally adverse or corrosive environments; such as near lakes, oceans or in areas with consistently high humidity conditions. Consult the paint manufacturers instructions for proper preparation and application.

TEN FOOT RULE SUMMARY

The minimum chimney height above the roof and/or to adjacent walls and buildings is specified by all major building codes.

If the horizontal distance from the peak of the roof is less than 10', the top of the chimney must be at least 2' above the peak of the roof.

If the horizontal distance from the chimney edge to the peak of the roof is more than 10' a chimney height reference point is established on the roof surface 10' horizontally from the chimney edge. The top of the chimney must be at least 2' above this reference point. In all cases, the chimney cannot be less than 3' above the roof at the edge of the chimney.

The 2' in 10' rule is necessary in the interest of safety but does not ensure smoke-free operation. Trees, buildings, adjoining roof lines, adverse wind conditions, etc., may require a taller chimney should the fireplace not draft properly (refer to **Figure 43**).

MULTIPLE TERMINATIONS

If more than one termination is located in the same chase or within the same general proximity, we suggest they should be separated in distance at least 24" horizontally from flue center to flue center and stacked or staggered vertically at least 18" apart, from the termination of one smoke exit to the termination of another smoke exit (**Figure 44**).

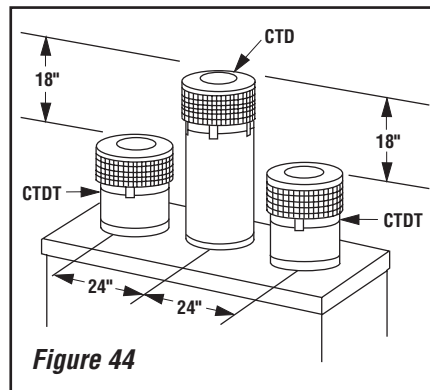

Figure 44

This suggestion is provided in the interest of better operation. If the terminations are located too close to each other, smoke may migrate from one flue into the other.

FTF8 CHIMNEY COMPONENT CALCULATIONS

The minimum installed height of the completed fireplace system is 15' 0" for indoor installations and 7' 9" for outdoor installations. The maximum height is 60' 0."

To determine the number of chimney sections and chimney components required, follow these steps:

1. Determine total vertical height of the fireplace installation. This dimension is the distance from the surface the fireplace sets on to the point where smoke exits from the termination.
2. Determine the number of chimney components required, except chimney sections. This would include firestop spacers, stabilizers, roof flashing, etc.
3. The effective heights of the components are:

The Fireplace	=	42-1/4"
FTF8-12	=	10-1/4"
FTF8-18	=	16-1/4"
FTF8-36	=	34-1/4"
FTF8-48	=	46-1/4"
** FTF8-CTD Termination	=	4"
FTF8-CT1 Termination	=	12" to 18"
FTF8-CT2 Termination	=	15" to 23"
** FTF8-CTDT Termination	=	12" to 18"
FTF8-CTDTM Termination	=	4"
FTF8-S4 Stabilizer *	=	3"*

* Required for every 30' of vertical chimney and/or 10' of offset chimney.

****FTF8-CT1 and FTF8-CTDT Terminations are approved for indoor fireplace installations only.**

4. Determine amount of chimney height required by subtracting total combined height of all pre-selected components (fireplace and chimney components from total desired height).

Reference Vertical Elevation Chart and determine the number of chimney sections (quantity and length) required.

SPECIAL OFFSET INSTRUCTIONS

To clear any overhead obstructions, you may offset your chimney system using Security Chimneys 30° offset and return elbows. Use two elbows - an offset elbow to initiate the offset and a return elbow to terminate it. A 30° offset elbow, angling in any direction, may be the first component used off the top of the fireplace flue collar.

The offset and return elbows may be attached together, or a section or sections of chimney may be used between, but do not exceed 20' in total length between elbows. If sections of pipe exceed 10' between elbows, a chimney stabilizer must be used at the midpoint (**Figure 45**). The stabilizer support straps must be attached under tension (in shear) to structural framing members above. When two sets of elbows are used, the maximum combined length of chimney used between elbows cannot exceed 20' (**Figure 46**). **Example:** If $C_1 = 10'$ then C_2 cannot exceed 10'.

If an offset exceeds 6' in length, each chimney joint beyond the first 6' of offset to the return elbow, must be secured by a No. 8 x 1/2" sheet metal screw located at the underside of the joint (**Figure 47**).

A 1/8" diameter hole must be drilled in the chimney joint using a 1/8" diameter drill. The hole should be drilled in center of joint overlap (**Figure 48**). Be sure to drill only through the outer chimney casting. Do not puncture the inner flue.

Maximum offset of chimney system is 30°. Two offsets must not be assembled to form a 60° offset. However, two sets of offset and return elbows may be used on a single flue system, provided the total height of the system exceeds 25'.

Return elbow support straps must be securely attached under tension (in shear) to structural framing members above. Do not substitute a FTF8-30 offset elbow in place of a FTF8-E30 return elbow.

OFFSET CALCULATIONS

Step 1. Use the Offset Chart (**Table 4**) to determine amount of horizontal offset (A) and height (B) for various chimney section assemblies.

Step 2. Use "Height of Chimney Only" column in The Vertical Elevation Chart to determine combinations of chimney used above return elbow to achieve desired heights. Reference Components Effective Height Chart in vertical elevation chart section.

Step 3. Use Elevation Chart as job estimator only. Add necessary firestop spacers and stabilizers as required. Firestop spacers must be used as shown in **Figures 31 & 32** and stabilizers as shown in **Figure 37**.

FTF8 Vertical Elevation Chart
11" to 380 1/2"

Inches	Feet/Inches	12"	18"	36"	48"
11	0 11	1	0	0	0
17	1 5	0	1	0	0
21 1/4	1 9 1/4	2	0	0	0
27 1/4	2 3 1/4	1	1	0	0
35	2 11	0	0	1	0
47	3 11	0	0	0	1
51 1/4	4 3 1/4	0	1	1	0
57 1/4	4 9 1/4	1	0	0	1
63 1/4	5 3 1/4	0	1	0	1
67 1/4	5 7 1/4	2	0	0	1
73 1/4	6 1 1/4	1	1	0	1
81 1/4	6 9 1/4	0	0	1	1
93 1/4	7 9 1/4	0	0	0	2
97 1/4	8 1 1/4	0	1	1	1
102 1/2	8 6 1/2	1	0	0	2
109 1/4	9 1 1/4	0	1	0	2
113 1/2	9 5 1/2	2	0	0	2
119 1/2	9 11 1/2	1	1	0	2
127 1/4	10 7 1/4	0	0	1	2
137 1/2	11 5 1/2	1	0	1	2
139 1/4	11 7 1/4	0	0	0	3
143 1/2	11 11 1/2	0	1	1	2
149 1/2	12 5 1/2	1	0	0	3
155 1/2	12 11 1/2	0	1	0	3
159 3/4	13 3 3/4	2	0	0	3
165 3/4	13 9 3/4	1	1	0	3
173 1/2	14 5 1/2	0	0	1	3
183 3/4	15 3 3/4	1	0	1	3
185 1/2	15 5 1/2	0	0	0	4
189 3/4	15 9 3/4	0	1	1	3
195 3/4	16 3 3/4	1	0	0	4
201 3/4	16 9 3/4	0	1	0	4
206	17 2	2	0	0	4
212	17 8	1	1	0	4
219 3/4	18 3 3/4	0	0	1	4
230	19 2	1	0	1	4
231 3/4	19 3 3/4	0	0	0	5
236	19 8	0	1	1	4
242	20 2	1	0	0	5
248	20 8	0	1	0	5
252	21 0	2	0	0	5
258	21 6	1	1	0	5
266	22 2	0	0	1	5
276	23 0	1	0	1	5
278	23 2	0	0	0	6
282	23 6	0	1	1	5
288	24 0	1	0	0	6
294 3/4	24 6 3/4	0	1	0	6
298 1/4	24 10 1/4	2	0	0	6
304 1/4	25 4 1/4	1	1	0	6
312	26 0	0	0	1	6
322 1/4	26 10 1/4	1	0	1	6
324	27 0	0	0	0	7
328 1/4	27 4 1/4	0	1	1	6
334 1/4	27 10 1/4	1	0	0	7
340 1/4	28 4 1/4	0	1	0	7
344 1/2	28 8 1/2	2	0	0	7
350 1/2	29 2 1/2	1	1	0	7
358 1/4	29 10 1/4	0	0	1	7
368 1/2	30 8 1/2	1	0	1	7
370 1/4	30 10 1/4	0	0	0	8
374 1/2	31 2 1/2	0	1	1	7
380 1/2	31 8 1/2	1	0	0	8

Table 3a

FTF8 Vertical Elevation Chart
386 1/2" to 744"

Inches	Feet/Inches	12"	18"	36"	48"
386 1/2	32 2 1/2	0	1	0	8
390 3/4	32 6 3/4	2	0	0	8
396 3/4	33 0 3/4	1	1	0	8
404 1/2	33 8 1/2	0	0	1	8
414 3/4	34 6 3/4	1	0	1	8
416 1/2	34 8 1/2	0	0	0	9
420 3/4	35 0 3/4	0	1	1	8
426 3/4	35 6 3/4	1	0	0	9
432 3/4	36 0 3/4	0	1	0	9
437	36 5	2	0	0	9
443	36 11	1	1	0	9
450 3/4	37 6 3/4	0	0	1	9
461	38 5	1	0	1	9
462 3/4	38 6 3/4	0	0	0	10
466 3/4	38 10 3/4	0	1	1	9
472	39 4 3/4	1	0	0	10
478 3/4	39 10 3/4	0	1	0	10
483	40 3	2	0	0	10
489	40 9	1	1	0	10
496 3/4	41 4 3/4	0	0	1	10
507	42 3	1	0	1	10
508 3/4	42 4 3/4	0	0	0	11
513	42 9	0	1	1	10
519	43 3	1	0	0	11
525	43 9	0	1	0	11
529 1/4	44 1 1/4	2	0	0	11
535 1/4	44 7 1/4	1	1	0	11
543	45 3	0	0	1	11
553 1/4	46 1 1/4	1	0	1	11
555	46 3	0	0	0	12
559 1/4	46 7 1/4	0	1	1	11
565 1/4	47 1 1/4	1	0	0	12
571 1/4	47 5 1/4	0	1	0	12
575 1/2	47 11 1/2	2	0	0	12
581 1/2	48 5 1/2	1	1	0	12
589 1/4	49 1 1/4	0	0	1	12
599 1/2	49 11 1/2	1	0	1	12
601 1/4	50 1 1/4	0	0	0	13
605 1/2	50 5 1/2	0	1	1	12
611 1/2	51 11 1/2	1	0	0	13
617 1/2	51 5 1/2	0	1	0	13
621 1/2	51 9 1/2	2	0	0	13
627 1/2	52 3 1/2	1	1	0	13
635 1/2	52 11 1/2	0	0	1	13
645 1/2	53 9 1/2	1	0	1	13
647 1/2	53 11 1/2	0	0	0	14
651 1/2	54 3 1/2	0	1	1	13
657 1/2	54 9 1/2	1	0	0	14
663 1/2	55 3 1/2	0	1	0	14
667 3/4	55 7 3/4	2	0	0	14
673 3/4	56 1 3/4	1	1	0	14
681 1/2	56 9 1/2	0	0	1	14
691 3/4	57 7 3/4	1	0	1	14
693 1/2	57 9 1/2	0	0	0	15
697 3/4	58 1 3/4	0	1	1	14
703 3/4	58 7 3/4	1	0	0	15
709 3/4	59 1 3/4	0	1	0	15
714	59 6	2	0	0	15
720	60 0	1	1	0	15
727 3/4	60 7 3/4	0	0	1	15
738	61 6	1	0	1	15
739 3/4	61 7 3/4	0	0	0	16
744	62 0	0	1	1	15

Table 3b

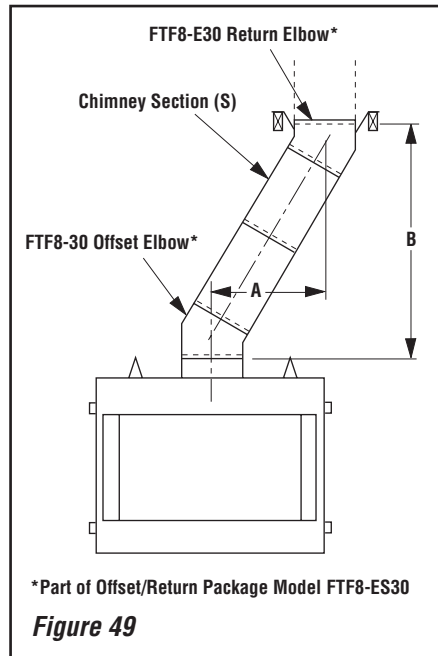
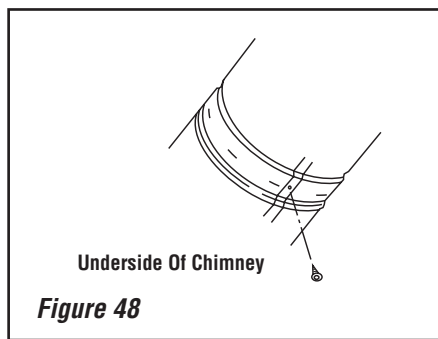
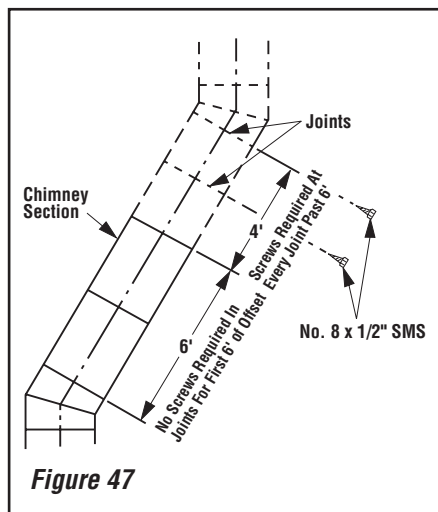
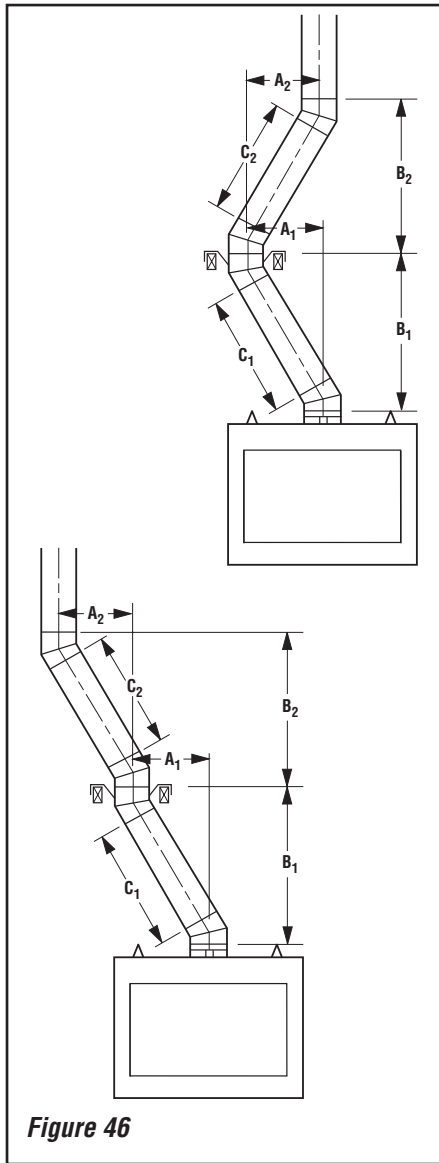
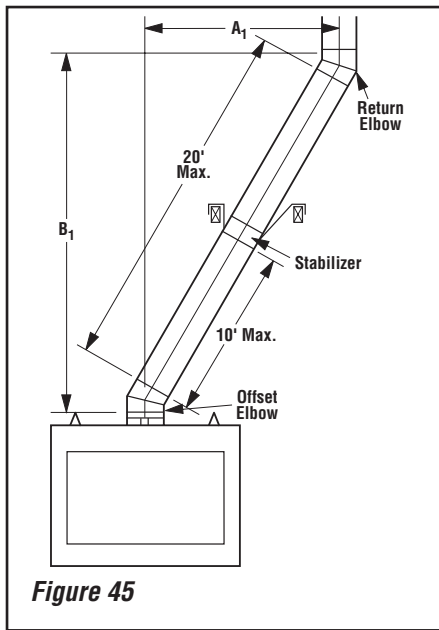

NOTE: DIAGRAMS & ILLUSTRATIONS ARE NOT TO SCALE.

INSTALLING OFFSETS

First, review the Offset Elevation Chart and **Figure 49** for reference.

Step 1. Determine the offset distance where chimney is to pass through the first ceiling-dimension "A." To find this point on your ceiling, first determine the center point for a vertical chimney following the instructions for vertical installation.

Measure height to the ceiling from the top of fireplace-dimension "B." Use the appropriate Offset Elevation Chart to find dimension "A." Mark point where you will drive your nail to show the center point for your offset ceiling cut.

Step 2. Proceed by using the Straight Up Installation Instructions for cutting and framing ceiling and roof openings.

Note: See Framing and Dimension Chart for the sizes of the ceiling and roof openings. The size of the roof opening varies with the degree of pitch of the roof.

Offset Elbow Assembly

Offset elbows install the same as chimney sections. First, snap the inner section INTO the preceding inner section of flue. Check connection by pulling up slightly to ensure a tight fit. Next, the outer sections snap lock OVER the preceding outer section of chimney. Again, check outer section by pulling up slightly to ensure proper connection is made.

Return Elbow Assembly

Return elbows install the same way as round terminations and stabilizers:

- Step 1.** Hold return elbow over top of last chimney section.
- Step 2.** Center inner slip section into inner flue pipe-slip down.
- Step 3.** Center outer-locking section over outer chimney pipe. Push down until locking joint has firmly engaged.
- Step 4.** Pull up slightly on return elbow to ensure locking joint has firmly engaged.
- Step 5.** Secure support straps to framing members by nailing under tension in shear (**Figure 50**).

Offset Elevation Chart

A Offset (Inches)	B Height (Inches)	FTF8-ES30 Offset/Return Elbow	FTF8-S4 Stabilizer	Number of FTF8 Chimney Sections			
				12"	18"	36"	48"
4	15 ¾	1	0	0	0	0	0
9	24 ½	1	0	1	0	0	0
12	29 ¾	1	0	0	1	0	0
14 ¼	33 ½	1	0	2	0	0	0
17 ¼	38 ½	1	0	1	1	0	0
20 ¼	43 ¾	1	0	0	2	0	0
21	45 ¼	1	0	0	0	1	0
22 ¼	47 ½	1	0	2	1	0	0
25 ¼	52 ½	1	0	1	2	0	0
26 ¼	54 ¼	1	0	1	0	1	0
27	55 ¾	1	0	0	0	0	1
28 ¼	57 ¾	1	0	0	3	0	0
29 ¼	59 ¼	1	0	0	1	1	0
31 ¼	63	1	0	2	0	1	0
32 ¼	64 ½	1	0	1	0	0	1
34 ¼	68 ¼	1	0	1	1	1	0
35 ¼	69 ¾	1	0	0	1	0	1
37 ¼	73 ¼	1	0	0	2	1	0
38 ¼	75	1	0	0	0	2	0
39 ¼	77	1	0	2	1	1	0
41 ½	80 ½	1	0	1	4	0	0
43 ¼	83 ¾	1	0	1	0	2	0
44 ¼	85 ¼	1	0	0	0	1	1
45 ¼	87 ½	1	0	0	3	1	0
46 ¼	89	1	0	0	1	2	0
48 ¼	91 ½	1	0	2	0	2	0
49 ¼	94 ¼	1	0	1	0	1	1
50 ¼	95 ¾	1	0	0	0	0	2
51 ¼	97 ¾	1	0	1	1	2	0
54 ¼	103	1	0	0	2	2	0
55 ¼	104 ½	1	0	1	0	0	2
56 ½	106 ½	1	0	2	1	2	0
58 ¼	109 ¾	1	0	0	1	0	2
61 ¾	116	1	1	1	0	3	0
64 ¾	121 ¼	1	1	0	1	3	0
67	124 ¾	1	1	2	0	3	0
68 ¾	128	1	1	0	0	1	2
70	130	1	1	1	1	3	0
73	135 ¼	1	1	0	2	3	0
74 ¾	138 ¼	1	1	0	0	0	3
79	145 ½	1	1	1	0	4	0
80	147 ¼	1	1	1	0	0	3
82	150 ¾	1	1	0	1	4	0
82 ¼	152	1	1	0	1	0	3

Table 4

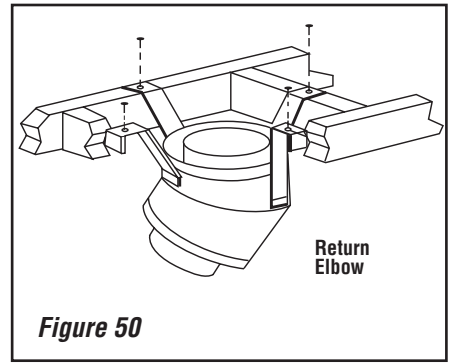

Figure 50

Note: The return elbow assembly performs the same function as a stabilizer. Consider this when determining the need for a stabilizer.

Note: Do not apply excessive pressure to any subsequent chimney section following return elbow assembly when installing. Ensure that each subsequent chimney section is securely attached by testing as noted above.

Gas Line Connection

Install a 1/2" gas supply line through fireplace wall for connection to a decorative gas appliance inside the firebox. Outside, the gas supply line connects to a gas shut-off valve recessed flush into the wall or floor. The valve should be controlled by a removable valve key for safety.

Always plumb gas line installation per local codes. Check all connections with a gas leak detection solution for leaks (which will bubble if present). Never test any gas line connection with a match or open flame.

This provision is intended for connection to a decorative gas appliance incorporating an automatic shut-off device and complying with the Standard for Decorative Gas Appliances for installation in vented fireplaces, ANSI Z21.60 (1991) or American Gas Association draft requirements for Gas-Fired Log Lighters for Wood Burning Fireplaces, Draft No. 4 dated August, 1993. Install in accordance with the National Fuel Gas Code, ANSI Z223.1. This complies with the revised U.L. 127 standard.

Vent Free Appliances

This unit has been tested and approved to ANSI/IAS/AGA Z21.11.2 for use with unvented gas appliances for INDOOR INSTALLATIONS ONLY and complies with the standard for Factory-Built fireplaces, UL 127, when installed with unvented gas log sets.

Special instructions with regards to mantel installations must be taken into consideration when installing such appliances.

The unit has been tested for use with any unvented log sets having a maximum rating of 26,000 BTU in Indoor installations only. The minimum mantel configuration for these log sets are outlined in *Figure 52*.

Log sets with 40,000 BTU may be installed provided that no combustible mantel projections are placed lower than 18 inches from the fireplace opening.

These fireplaces have been marked with a maximum rating of 26,000 BTU to assure that homeowners do not exceed the allowable limits for all allowed installations of mantels. That limit may be increased to 40,000 BTU, provided that the mantel installed complies with the 18-inch limitation and a copy of these instructions are available.

IMPORTANT

Allow minimum 1" * chimney air space to combustible framing members throughout vertical or offset chimney installation.

ATTENTION

Permettez 1 minimal" * l'espace aérien de cheminée aux membres encadrants combustibles partout dans vertical ou à l'installation de cheminée de rejeton.

**Note: In Canada, a 2" clearance to combustibles is required.*

• *Outdoor installations less than 15' height require chimney clearance of 2" air space to insulation and construction materials.*

WARNING

Unvented Gas Log Sets are not approved for use with fireplaces installed outdoors. The materials and components will deteriorate prematurely if installed outside. Refer to the log manufacturer's literature for limitations and exceptions.

AVERTISSEMENT

Les ensembles de bûches à gaz sans conduit d'évacuation ne sont pas approuvés pour l'usage avec des foyers installés à l'extérieur. Les matériaux et les composants se détérioreront prématurément si installés à l'extérieur. Référez-vous à la littérature du fabricant des bûches pour les limites et les exceptions.

CAUTION

Plumbing connections should only be performed by a qualified, licensed plumber. Main gas supply must be off when plumbing gas line to fireplace or performing service.

ATTENTION

Les raccordements de tuyauterie devraient seulement être effectués par un plombier qualifié et autorisé. La valve d'alimentation de gaz principale doit être fermée lors de l'installation ou de l'entretien de ce foyer.

If you're installing a gas line, connect it before the fireplace is framed and enclosed in the finished wall. The gas knockout is determined by the indentation located at the bottom and slightly off center in the side refractories. **THE KNOCKOUT IS ALWAYS REMOVED FROM INSIDE THE FIREPLACE. DO NOT REMOVE THE KNOCKOUT UNLESS YOU ARE INSTALLING A GAS LINE.** If removal is attempted from the outer wrapper, side refractory damage may occur. With a medium-sized hammer, lightly tap the surface of the indentation. The refractory material is very thin in this area and is easily removed. Once a small hole has been made, continue tapping until you have reached sufficient diameter for the gas line to fit through. The entire knockout does not have to be removed. Remove insulation in the gas line channel.

IMPORTANT: REPACK INSULATION MATERIAL IN SQUARE HOLE AROUND GAS LINE, INTERIOR AND EXTERIOR OF FIREPLACE, TO SEAL.

Glass Doors

If glass doors are to be installed on these fireplaces, refer to specific installation instructions packed with the glass doors. Use only the doors that are listed for use with these fireplaces. Use of other non-listed glass door on these fireplaces may constitute a potential fire hazard and is not recommended.

CAUTION

Certain glass doors overlap the black metal facing of the fireplace. IF the fireplace has been faced with noncombustible materials, there might not be sufficient clearance to install the glass doors of your choice. Ensure adequate clearance is maintained at all times so as not to interfere with the installation and operation of glass doors.

! ATTENTION

Certaines portes de verre recouvrent le revêtement noir en métal du foyer. Si la façade du foyer a été recouverte avec des matériaux non-combustibles, il se pourrait qu'il n'y ait pas suffisamment de dégagement pour installer les portes de verre de votre choix. Assurez d'avoir un dégagement suffisant à tout moment afin de ne pas interférer avec l'installation et l'opération des portes de verre.

COLD CLIMATE INSULATION

If you live in a cold climate, it is especially important to seal all cracks around the fireplace opening with noncombustible material and wherever cold air could enter the room. Surrounding materials must be caulked where it meets the black metal facing of the fireplace to avoid cold air intrusion. Use noncombustible caulking material only on fireplace facing to seal. Also, the outside air inlet duct should be wrapped with noncombustible insulation to minimize the formation of condensation. Do not place insulation materials on top of fireplace or against chimney sections. If gas logs are installed, the gas line holes and other openings should be caulked with high temperature caulk or stuffed with unfaced fiberglass insulation.

Note: A 1" air space must be preserved for insulation and construction materials extending for any continuous length adjacent to the chimney.

It is especially important to insulate between the studs of an outside chase cavity and under the floor if the floor is above ground level. Do not place insulation directly against the fireplace or chimney system.

FIREPLACE FINISHES

Mantels and Trim

It is sometimes best to frame your fireplace after it is positioned and the chimney is installed. Frame enclosure for chimney and fireplace with 2 x 4's (or heavier) lumber.

Note: The header may touch but not rest its weight on the two (2) metal top spacers on top of the unit. The header must not be notched to fit around the spacers.

These fireplaces may sit directly on a combustible surface. A 1" air space is required between insulation and construction material and the chimney. A 1" air space is required between combustible framing and fireplace outer wrapper.

In Canada, the minimum height for a combustible mantel is 18" (457 mm) above the fireplace opening. **Figure 51** shows typical Canadian installations. Combustible mantels and trim may be installed 12" above the fireplace opening as per NFPA 211-latest edition, and **Figure 52**. If a mantel is of a noncombustible material, it is exempt from these requirements as long as it does not interfere with the installation or operation of glass doors.

***Note:** 2" clearance to combustibles required in Canada.

Note: Do not place any combustible materials on the fireplace face.

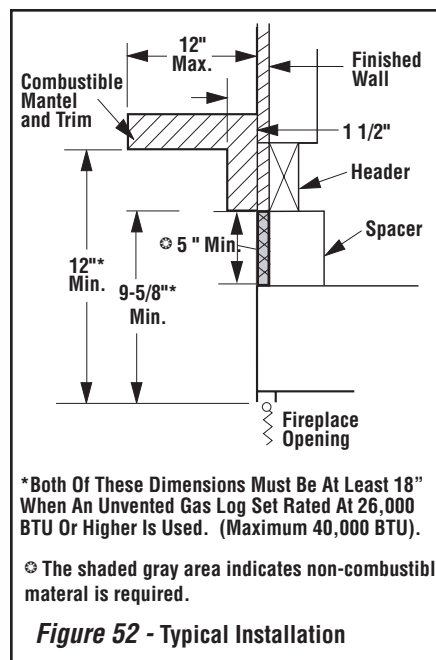
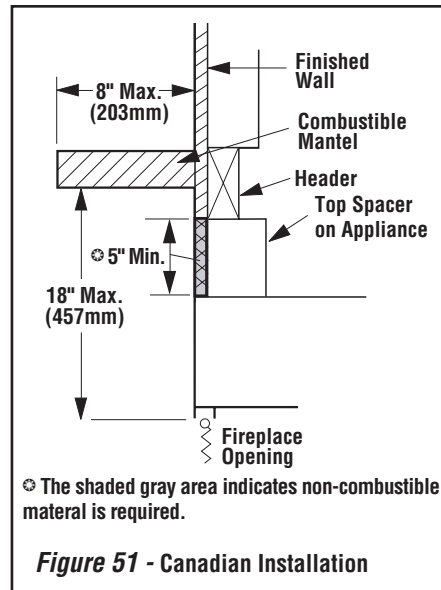

***Both Of These Dimensions Must Be At Least 18" When An Unvented Gas Log Set Rated At 26,000 BTU Or Higher Is Used. (Maximum 40,000 BTU).**

• The shaded gray area indicates non-combustible material is required.

! WARNING

Only non-combustible materials are allowed on front face (front fireplace frame) and around the perimeter within 5" minimum on top and 1/2" on sides.

! AVERTISSEMENT

Seulement on permet des matériaux non-combustibles sur le visage avant (armature avant de cheminée) et autour du périmètre à moins de 5 pouces sur le dessus et de pouce de 1/2 des côtés.

Hearth Extensions and Wall Shields

A hearth extension must be installed with all fireplaces. It is to protect the combustible floor in front of the fireplace from both radiant heat and sparks. The hearth extension must extend 8" beyond both sides of the fireplace opening and 16" beyond the front (see **Figure 53**). Use a hearth extension constructed of a durable noncombustible material having an equal or better (lower k value) insulating value of $k = .84 \text{ BTU IN/FT}^2 \text{ HR } ^\circ\text{F}$ or a thermal resistance that equals or exceeds $r = 1.19 \text{ HR } ^\circ\text{F FT}^2/\text{BTU IN}$. With these values, determine the minimum thickness/material required using the formula and **Table 5** on **Page 21**.

Note: Any noncombustible material having a thickness of 1" whose k value is less than .84 or whose r value is more than 1.19 is acceptable.

If the fireplace is installed on a combustible floor, use the metal safety strips (provided) on the floor extending half under the fireplace and half under the hearth extension (refer to **Figures 21 & 22**).

A wall shield is required where a continuous perpendicular side wall is within 12" of the fireplace opening (**Figure 53**). Use a 24" W x 30" H x 1/2" wall shield constructed of a durable, noncombustible material having an equal or better (lower k value) insulating value than $k = .54 \text{ BTU IN/FT}^2 \text{ HR } ^\circ\text{F}$. At no time may a perpendicular side wall be located closer than 7" from the fireplace opening.

If fireplace is installed diagonally across a 90° corner; no wall shields are required.

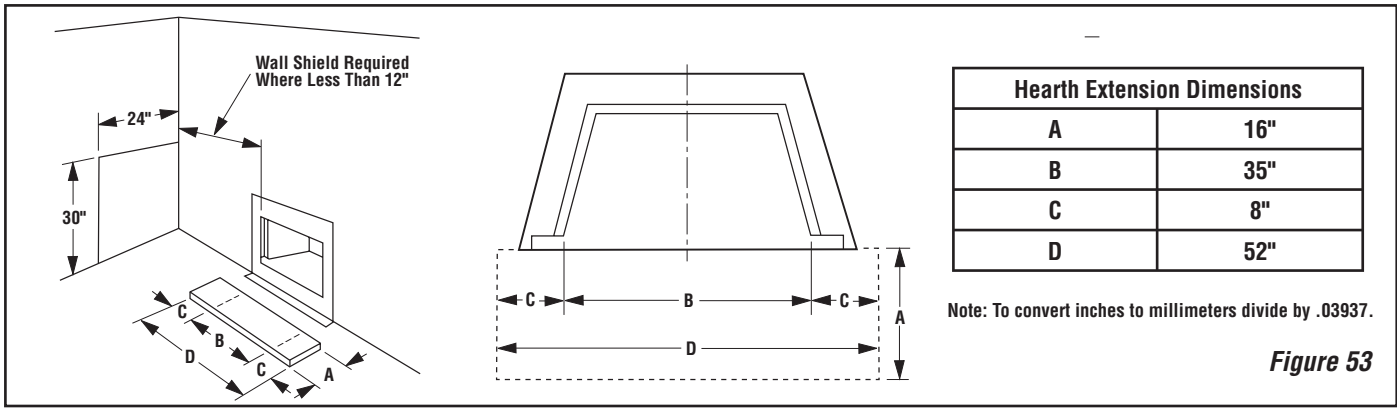

Hearth Extension Dimensions	
A	16"
B	35"
C	8"
D	52"

Note: To convert inches to millimeters divide by .03937.

Figure 53

Methods of Determining Hearth Extension and Wall Shield Equivalents - To determine the thickness required for the alternate material when either the "k" value or "r" value is known, use either the **k formula** or **r formula**.

Example: If Micore 160 is to be used for the hearth extension fireplace, how thick must this material be?

- k_M = k value per inch of **alternate** material
- r_M = r value per inch of **alternate** material
- T_M = minimum thickness required for **alternate** material
- T_S = standard thickness of the **alternate** material
- k_L = k value per inch of **listed** material
- r_L = r value per inch of **listed** material
- T_L = minimum thickness of **listed** material

Note: An asterix "*" indicates, it is a value taken from **Table 5**.
Using the k formula:

Minimum thickness of alternate material (T_M)	=	k-value (per Inch) of alternate material (k_M) x k-value (per inch) of listed material (k_L)	x	Specified min. thickness of listed material (T_L)
T_M (inches)	=	$\frac{k_M}{*.84}$	x	T_L
T_M (inches)	=	$\frac{*.35}{*.84}$	x	1"
.416 (inches)=	=	.416	x	1"

Answer - The minimum required thickness of the Micore 160 is .417, "therefore round up to nearest standard thickness available which is 1/2."

Using the r formula:

Minimum thickness of alternate material	=	r-value (per Inch) of listed material x r-value (per inch) of alternate material	x	Specified min. thickness of listed material
T_M (inches)	=	$\frac{r_L}{r_M}$	x	T_L
T_M (inches)	=	$\frac{*1.19}{*2.86}$	x	1"
.417 (inches)=	=	.416	x	1"

Answer - The minimum required thickness of the Micore 160 is .417, "therefore round up to nearest standard thickness available which is 1/2."

Listed Material			
	k (per inch)	r (per inch)	Listed Min. Thickness
Listed Material	.84 k_L	1.19 r_L	1" T_L
** Approved Alternate Materials for Floor/Hearth Protection			
Alternative Materials	Thermal Values		Minimum Thickness (rounded to nearest 1/8 inch)
	k (per inch) k_M	r (per inch) r_M	Min. Thickness T_M
Kaowool M Board	.47	2.13	.56" (1/2")
Micore 160™ U.S. Gypsum	.35	2.86	.42" (3/8")
Micore 300™ U.S. Gypsum	.46	2.17	.55" (1/2")
Durock™ Cement Board U.S. Gypsum	1.92	.52	2.29" (2-1/4")
Hardibacker™	1.95	.513	2.32" (2-3/8")
Hardibacker 500™	2.30	.435	2.74" (2-3/4")
Cultured Stone Hearth-stone™	2.82	.355	3.36" (3-3/8")
Wonderboard	3.23	.31	3.85" (3-7/8")
Super Firetemp M Johns-Manville	.61	1.64	.73" (3/4")
Super Firetemp L Johns-Manville	.54	1.85	.64" (5/8")
Face brick	9.00	.111	10.71" (10-3/4")
Common brick	5.00	.20	5.95" (6")
Cement mortar	5.00	.20	5.95" (6")
Ceramic tile	12.5	.08	14.88" (14-7/8")
Marble	~11	~.09	13.10" (13-1/8")

Table 5

**** If the hearth extension material(s) that is intended to be used is NOT listed on Table 5, the material can still be used if the material(s) is noncombustible. However, the manufacturer of the material must provide either the listed k-value per inch or r-value per inch with listed thickness so that the minimum thickness required for the hearth can be calculated (per instructions on this Page and/or as specified in the NFI Certification manuals).**

Note: Also see NFI (National Fireplace Institute) Certification Manuals showing other acceptable calculation methods and acceptable alternate materials which can be used.

Calculating Minimum Thickness if Multiple Materials are Used

At times it is important to know what combination of materials are acceptable for use as floor protection. The "R values" are used to determine acceptable combinations of materials because "R values" are additive where r and k values are not.

"R value" = $1/k = "r" \times \text{thickness of material used}$

Example: Given that the required "R value" for a suitable floor protector used must be equal to or greater than:

$$"R" = r_L \times T_L = 2.33 \times 1" = 2.33."$$

If it is desired to elevate a marble hearth extension to a level of 5" or more above the floor surface. What combination of noncombustible materials can be used to accomplish this?

If common brick is used so that the 3 1/2" dimension is the height, "R" for the common brick becomes:

$$"R"_{\text{M}} = r_{\text{M}} \times T_{\text{S}} = \overset{\text{brick}}{0.20} \times 3 \frac{1}{2}" = .70$$

Using 1/2" of mortar to set the brick, "R" for the mortar is calculated as follows:

$$"R"_{\text{M}} = r_{\text{M}} \times T_{\text{S}} = \overset{\text{mortar}}{0.20} \times \frac{1}{2}" = .10$$

Next, a 3/4" marble slab set in 1/2" mortar covers the brick, "R" for the marble and mortar becomes:

$$"R"_{\text{M}} = r_{\text{M}} \times T_{\text{S}} = \overset{\text{marble}}{0.09} \times \frac{3}{4}" = .068$$

$$"R"_{\text{M}} = r_{\text{M}} \times T_{\text{S}} = \overset{\text{mortar}}{0.20} \times \frac{1}{2}" = .10$$

The sum of all "R values" is: .70 + .10 + .068 + .10 = .968

This would NOT be an acceptable combination of material for the hearth extension since the total calculated "R value" of the materials used is under the required "R value" of 2.33. An additional layer of insulating materials must be used.

Note: Also see NFI Certification Manuals for expanded explanation on calculating "R values" when multiple materials are used.

! WARNING

The crack between the fireplace and the hearth extension must be sealed with a noncombustible material.

! AVERTISSEMENT

La fente entre le foyer et l'extension d'âtre doit être scellée avec un matériel non-combustible.

! WARNING

When installing hearth extension in front of a non-circulating fireplace model, the fireplace must be raised if height of hearth extension exceeds 7" above the bottom of fireplace (Figure 54).

When installing the hearth extension be careful not to block the heat-circulating air inlet grill on circulating models.

! AVERTISSEMENT

En installant la prolongation de foyer devant un modèle decirculation de cheminée, la cheminée doit être augmentée si la taille de la prolongation de foyer excède 7" (pouces) au-dessus du fond de la cheminée (Figure 54).

En installant l'extension d'âtre faites attention à ne pas bloquer la grille d'entrée d'air sur les modèles à circulation d'air.

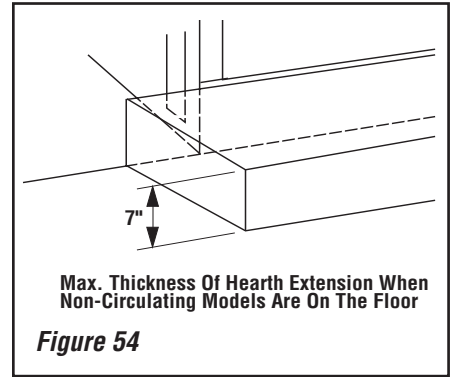

Secure the hearth extension to the floor to prevent possible shifting.

FINISH TO YOUR TASTE

There are a wide variety of "finished looks" for these fireplaces, from formal wall decor with elaborate mantels to rustic wood paneling or warm brick facings.

Only noncombustible materials like stone, tile, brick, etc., may overlap the black front facing. Do not extend these materials beyond the black facing and into the firebox area. Be sure not to interfere with the installation and operation of glass doors or block the upper or lower grilles. Seal all joints between the black facing and wall surrounds to prevent air intrusion. Use noncombustible caulking material only to seal the black metal facing to the surround material on the finished wall.

Combustible materials may project beyond the sides of the fireplace opening as long as they are kept within the shaded areas illustrated in Figure 55.

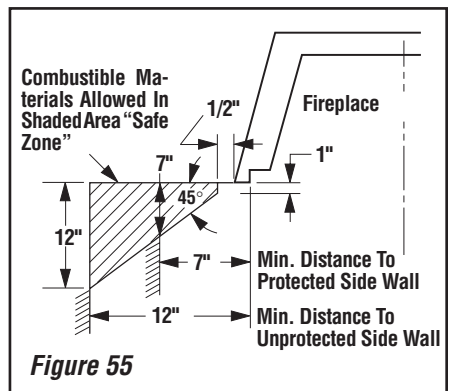

INSTALLATION COMPONENTS

The following items are available for use in the installation of this appliance.

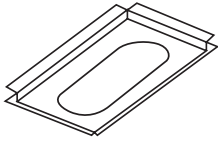

Firestop Spacer (30°)	63L30	F8FS30
Firestop Spacer (30°)	63L32	F8FS30-2
Firestop Spacer (45°) (Canadian)	63L33	FFS-45C

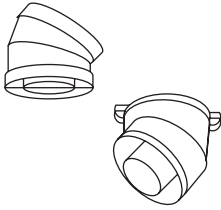

Offset/ Return Package (30°)	63L22	FTF8-ES30
45° Offset/Return Package (Canadian)	63L69	FTF8-ES45C

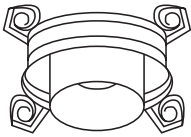

Stabilizer	63L25	FTF8-S4
------------	-------	---------

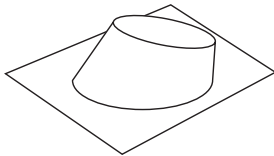

Flashing	63L38 63L39	F8F6 F8F12
----------	----------------	---------------



Chimney Section	63L10	FTF8-12
	63L13	FTF8-18
	63L14	FTF8-36
	63L15	FTF8-48

Canadian Chimney Section	62L92 62L93	FTF8-18C FTF8-36C
--------------------------	----------------	----------------------

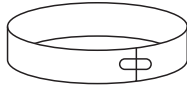

Ref. Form #750,080M

Locking Band	63L60	FLB
--------------	-------	-----

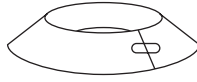

Storm Collar	63L59	FSC
Storm Collar (12 pack)	94L77	FSC-B-12

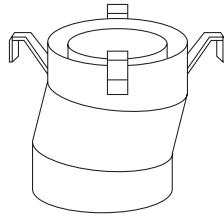

Ref. Form #750,012M

Combination Offset/Return Elbow	63L28	FTF8-OR15
---------------------------------	-------	-----------

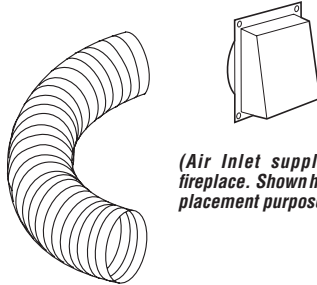

(Air Inlet supplied with fireplace. Shown here for replacement purposes only)

Ref. Form #750,191M

Outside Air Kit	H1964	OAK-OD
-----------------	-------	--------

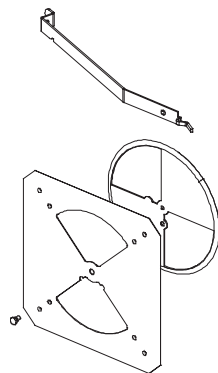

Ref. Form #750,198M

Air Gate is shown apart for illustration purposes only.

Air Gate Kit	H1972	OAKG-OD
--------------	-------	---------

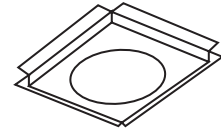

Firestop Spacer (Flat) (Single Pack)	63L29	F8FS
Firestop Spacer (Flat) (Single Pack)	63L31	F8FS-2
Firestop Spacer (Flat) (12 Pack)	94L76	F8FS-12

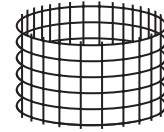

Spark Arrester	63L57	FSA-2
----------------	-------	-------

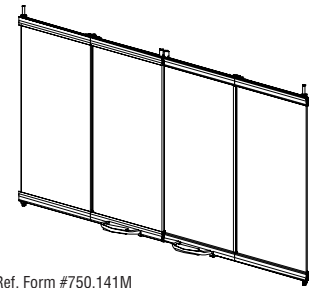

Ref. Form #750,141M

H1936	42ABFOD-BS	42" Bi-Fold door, Stainless
-------	------------	-----------------------------

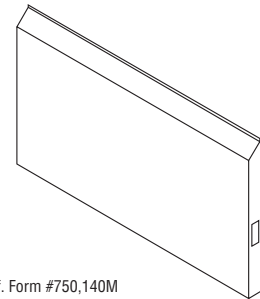

Ref. Form #750,140M

H1938	42-ODC	42" Stainless Weather Cover
-------	--------	-----------------------------

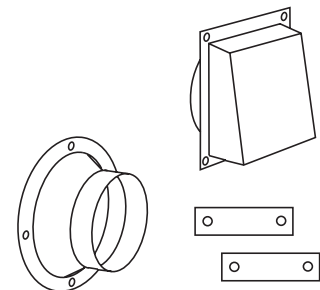

Ref. Form #750,081M

Cold Climate Kit	63L65	FTF8-CCK3-LD
------------------	-------	--------------

Indoor Installations Only

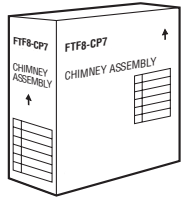

Contains:
 3 FTF8-36
 1 F8FS
 1 F8F6
 1 FTF8-CTD

Indoor Installations Only

Chimney Pack (conventional)
 Convenience Pack - Residential 63L70 FTF8-CP7

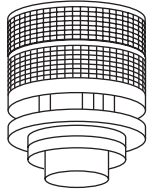

Chase Termination (Round) H0203 FTF8-CTDM

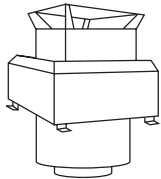

Chase Termination (Square) 63L51 FTF8-CT2

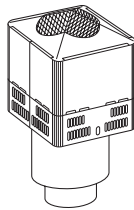

8" Open Top Termination (clay top termination)
 (For open top shrouds) 96L20 FTF8-CTT

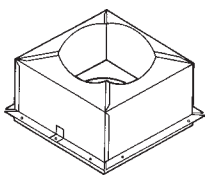

Attic Shield Assembly 63L67 FTF8-FSAS

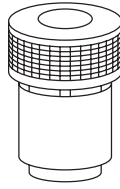

Indoor Installations Only

Ref. Form #750,014M

Chase Termination (Round) 63L45 FTF8-CTDT

Indoor Installations Only

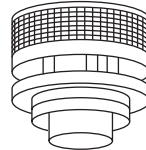

Contemporary Termination - Round 63L42 FTF8-CTD

Contemporary Termination - Round, Black H2238 FTF8-CTDP

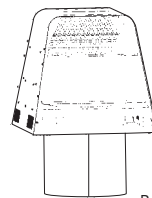

8" Arch Top Termination (For shrouds closed above) 96L22 FTF8-ATT

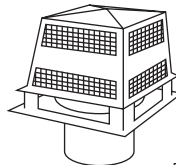

Chase Termination - Pyramid (Square) 63L48 FTF8-CT1
 Chase Termination - Pyramid, Black (Square) 91L79 FTF8-CT1P

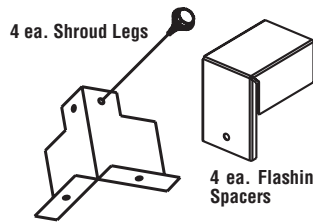

Termination Shroud Leg Kit H0911 SLK-4

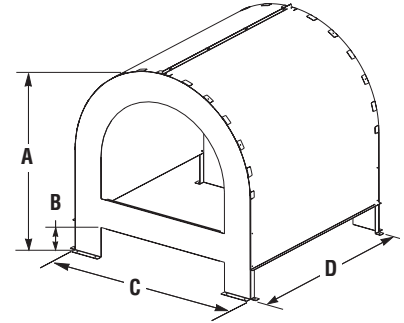

Ref. Form #750,194M

CLOSED TOP SHROUD TERMINATION KITS
 Inches (millimeters)

Cat. #	Model	A	B	C	D
H1988	CTSA-33	34" (864)	5" (127)	34" (864)	34" (864)

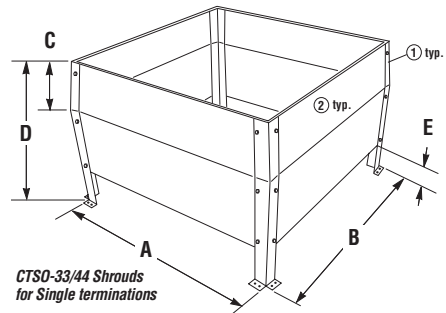
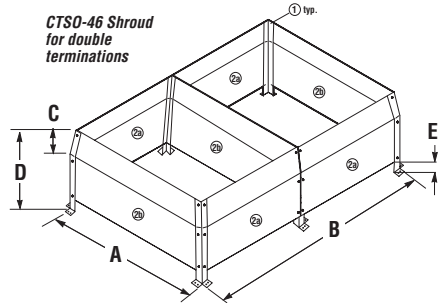

Ref. Form #750,193M

OPEN TOP SHROUD KITS
 Inches (millimeters)

Cat. #	Model	A	B	C	D	*E
H1985	CTSO-33	37-5/8 (955)	37-5/8 (955)	7-1/2 In. (191)	24-1/2 (622)	3 In. (76)
H1987	CTSO-44	48-5/8 (1235)	48-5/8 (1235)	7-1/2 In. (191)	24-1/2 (622)	3 In. (76)
H1986	CTSO-46	48-5/8 (1235)	73 1/4 (1860)	7-1/2 In. (191)	24-1/2 (622)	3 In. (76)

The manufacturer reserves the right to make changes at any time, without notice, in design, materials, specifications, prices and also to discontinue colors, styles and products. Consult your local distributor for fireplace code information.



HEARTH PRODUCTS

1110 West Taft Avenue
 Orange, CA 92865