



INSTALLATION INSTRUCTIONS FOR INSTALLING BLOWER KITS FOR USE WITH COUNTRY COLLECTION™ MODELS E260, C260, C310, C160, CA160, C210 AND CA210 WOOD FIREPLACE INSERTS

KIT CONTENTS

- 1 ea. Blower Assembly
- 1 ea. Instruction Sheet

TOOLS NEEDED

- 5/32 Allen Wrench Or T Handle Wrench
- 9/16" Socket Wrench
- 9/16" Open End Wrench
- 5/16" Open End Wrench
- Large Flat Head Screwdriver

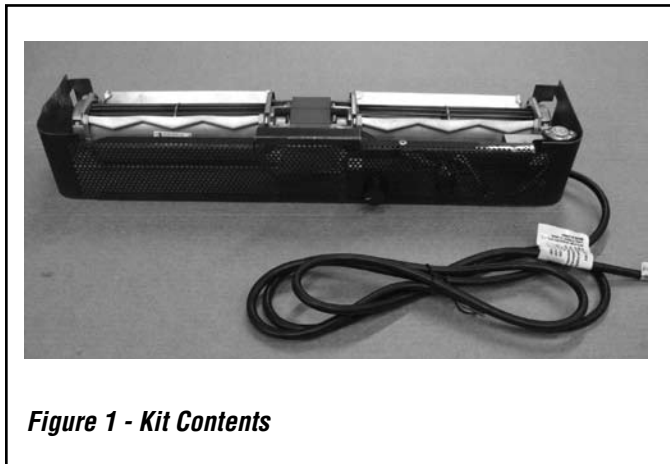

Figure 1 - Kit Contents

GENERAL INFORMATION

This optional blower kit can be installed to improve hot air distribution throughout the room. The room air circulation blower kit comes with a variable speed control (rheostat) and an snap switch which will provide automatic thermal activation of the blower, when desired (see *Blower Operation on Page 4*).

If you encounter any problems, need clarification of these instructions or are not qualified to properly install this kit, contact your local distributor or dealer.

Read this instruction sheet in its entirety before beginning the installation.

ALL WARNINGS AND PRECAUTIONS IN THE INSTALLATION AND OPERATION MANUAL PROVIDED WITH THE APPLIANCE APPLY TO THESE INSTRUCTIONS.

SHUT DOWN THE INSERT AND ALLOW IT TO COMPLETELY COOL BEFORE PROCEEDING.

⚠ WARNINGS

The blower must be plugged directly into a properly grounded three-prong receptacle, 120 VAC, 60 Hz, single phase. Do not cut or remove the grounding prong from this plug. Do not route power cord under or in front of appliance.

Installation must be in accordance with National Electrical Code, ANSI/NFPA 70 - latest edition. In Canada, the current CSA C22-1 Canadian Electrical Code - latest edition.

DANGER: Disconnect power before servicing blower.

BLOWER KITS FOR MODELS C160, CA160, C210 AND CA210		
Cat. No.	Model	Description
H7907	WSINS-BLWR-B-SS	Blower Insert Black
H7908	WSINS-BLWR-G-SS	Blower Insert Gold
H7909	WSINS-BLWR-N-SS	Blower Insert Nickel
H7910	WSINS-BLWR-BN-SS	Blower Insert Brushed Nickel
H7911	WSINS-BLWR-BG-SS	Blower Insert Brushed Gold

BLOWER KITS FOR MODELS E260, C260, AND C310		
Cat. No.	Model	Description
H7912	WLINS-BLWR-B-SS	Blower Insert Black
H7913	WLINS-BLWR-G-SS	Blower Insert Gold
H7914	WLINS-BLWR-N-SS	Blower Insert Nickel
H7915	WLINS-BLWR-BN-SS	Blower Insert Brushed Nickel
H7916	WLINS-BLWR-BG-SS	Blower Insert Brushed Gold

INSTALLATION INSTRUCTIONS

Install Blower Assembly

- Step 1.** Remove the contents from the blower kit.
Step 2. Place grommet with power cord into lower slot on desired side of insert. See **Figure 2**.



Figure 2

- Step 3.** Loosen the two blower mounting bolts below ash lip on both sides of front of insert, with 9/16" wrench. See **Figure 3**.

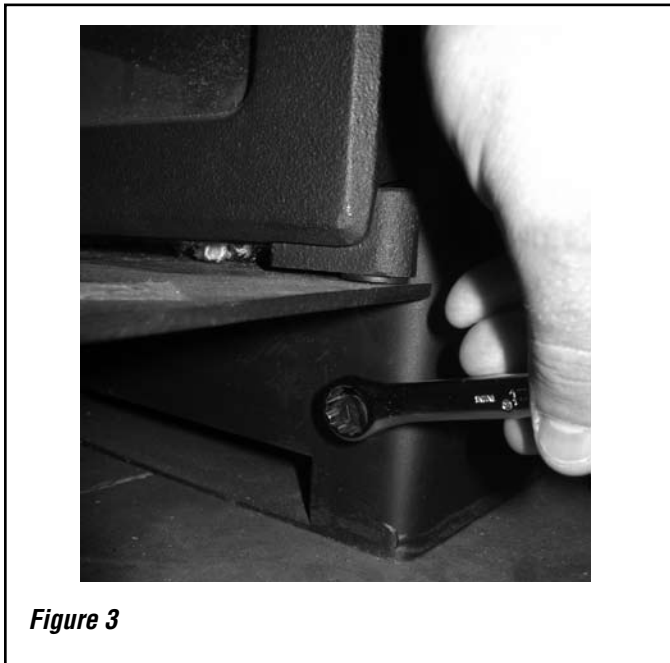

Figure 3

- Step 4.** Notice the corresponding slots on the rear of blower cage. See **Figure 4**.

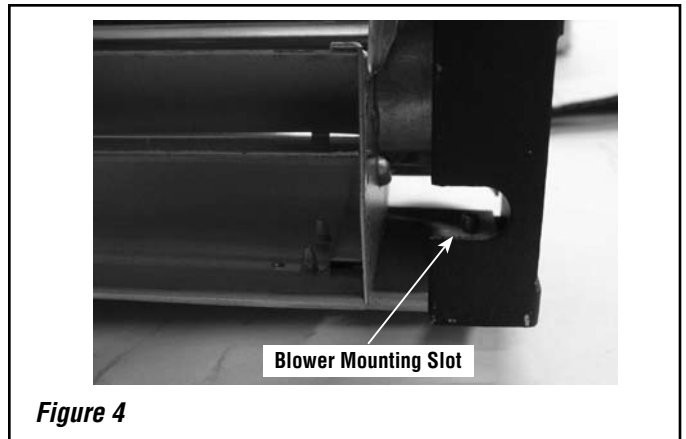

Figure 4

- Step 5.** Insert blower under the ash lip making sure that the slots in the blower housing line up to the left side of bolts. Gently slide blower housing from left to right over the loosened bolts until you feel it hit a solid stop and the housing is centered under the ash lip of the insert. See **Figure 5**.

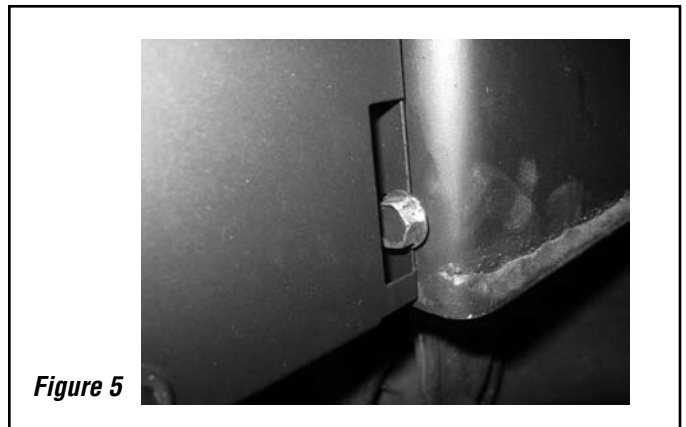

Figure 5

- Step 6.** Visually inspect and confirm that the snap switch is flat against the bottom side of the ash lip.

- Step 7.** After installing blower, If snap switch height adjustment is necessary, remove blower, and with a 5/16" wrench, loosen snap switch bracket nuts, and adjust up or down. When complete, re-tighten bracket nuts and re-install blower.

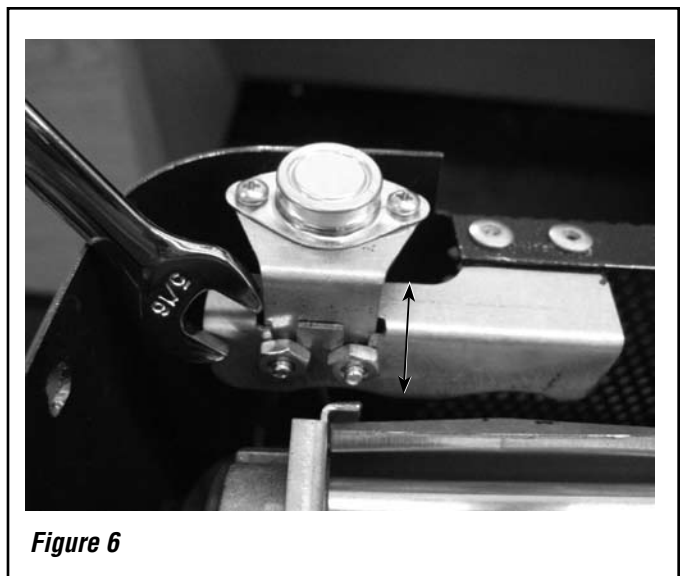

Figure 6

Step 8. Tighten bolts. See *Figure 7*.



Figure 7

Step 9. Re-check snap switch position to ensure good surface contact. Surface contact is critical to the optimal operation of the switch.

Step 10. Plug the power cord into a grounded 120 VAC receptacle. Do not route the power cord under the appliance or allow it to come in contact with any surface of the appliance.

Step 11. INSTRUCTIONS FOR MODEL E260 ONLY -

- a. Remove the existing draft rod knob.
- b. Install the supplied draft rod extension through the bracket attached to the bottom of the left side hearth plate, making sure the end without the grooves is toward the insert body. Thread the coupling nut on the end closest to the insert body and then thread the coupling nut on the rod from the insert.
- c. Locate the blower and blower extensions (see *Figure 8*). Slide the blower partially under the hearth plate. Run the blower cord through the slot in the blower housing extension on the appropriate side. Slide the left housing extension over the draft rod on the left side and slide the right housing using the method described below (the ends without the cord slots attach to the blower housing). Now slide the blower assembly under the hearth plate and center it.

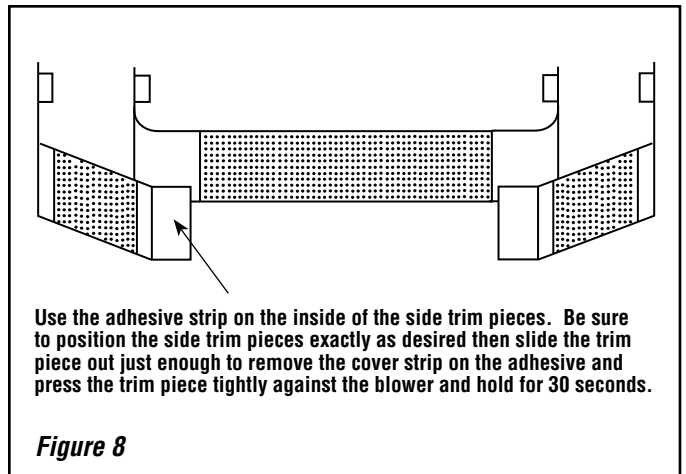

Use the adhesive strip on the inside of the side trim pieces. Be sure to position the side trim pieces exactly as desired then slide the trim piece out just enough to remove the cover strip on the adhesive and press the trim piece tightly against the blower and hold for 30 seconds.

Figure 8

Blower Operation

The blower can be operated manually or automatically (blower will turn on when the insert is hot and turn off when the insert is cool).

The rocker switch on the control panel allows you to select between manual operation or automatic operation as follows (see **Figure 10**):

MANUAL OPERATION: Turn rocker switch to the manual position (up) and adjust rheostat knob to the desired speed. The blower will have to be manually turned "OFF" by rotating the rheostat knob counterclockwise until it clicks.

AUTO OPERATION: Turn rocker switch to the "AUTO" position and the rheostat to the ON position (rotate rheostat knob clockwise until it clicks). When the insert warms up, the blower will automatically turn on (adjust rheostat knob to the desired speed setting). When the insert cools down, the blower will automatically turn off.

Rheostat Operation - The highest blower speed is obtained by turning the rheostat knob clockwise until it clicks "ON", then rotate towards "HIGH" to increase blower speed. Rotate the knob clockwise for a lower speed. To turn off, continue to rotate the knob counterclockwise until it clicks "OFF."

Blower Operation Guidelines

While in auto operation mode, the blower will turn off and on based on the temperature of the stove. Auto operation ensures there is sufficient heat build-up to warm the air being moved by the blower before the blower is

turned on. Likewise, when the stove cools off, the blower is turned off to prevent circulating cool air. Depending on the size and intensity of the fire it may be necessary to adjust the fan speed accordingly to ensure uninterrupted fan operation. For example a small fire may require a slower fan speed to keep the heat output by the fan consistent. If the blower is operated in manual mode, it may be necessary to adjust the blower speed as the fire begins to burn down and the stove is no longer hot enough to effectively heat the air moved by the blower. If the air coming from the blower feels cool, one should either decrease the blower speed or stoke the fire to build up more heat.

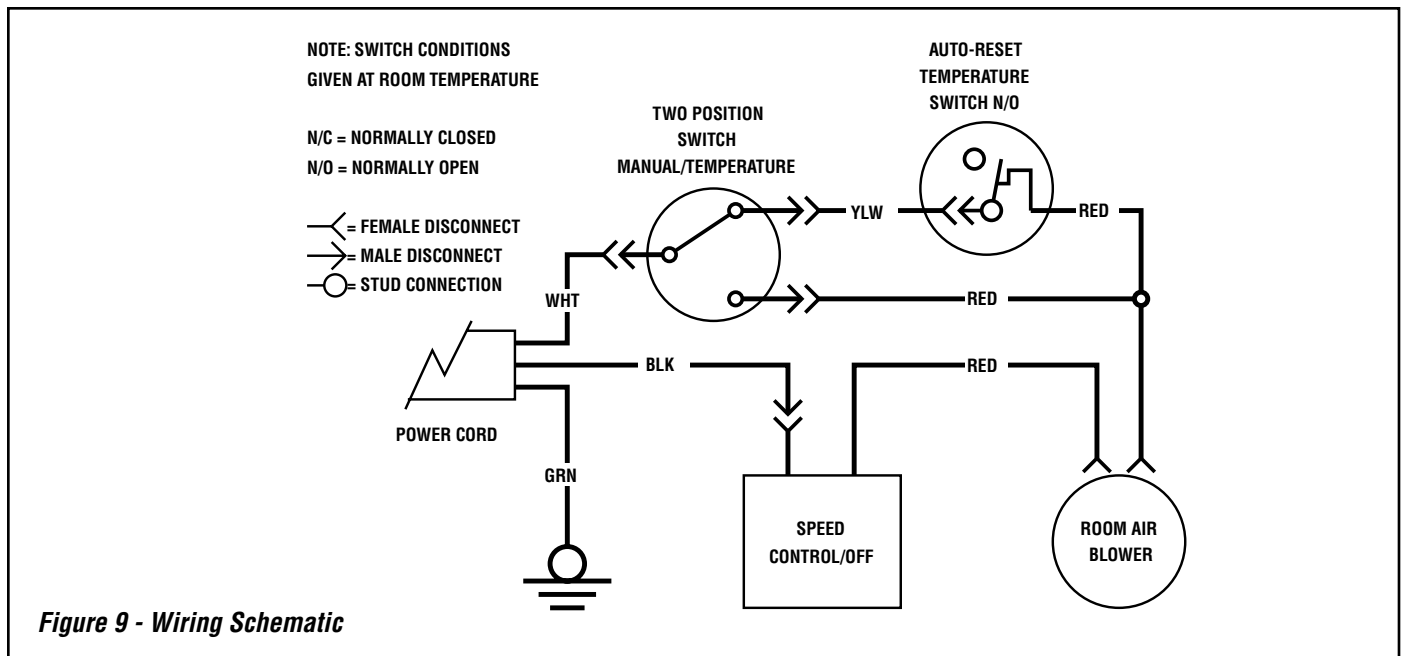
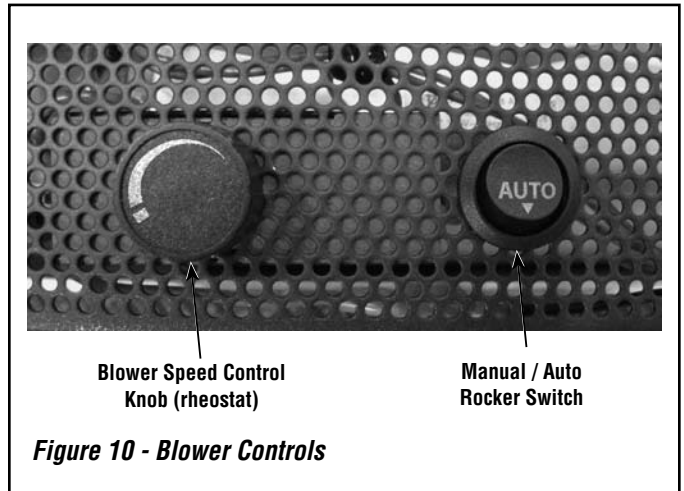

NOTE: DIAGRAMS & ILLUSTRATIONS ARE NOT TO SCALE.

Lennox Hearth Products reserves the right to make changes at any time, without notice, in design, materials, specifications, prices and also to discontinue colors, styles and products. Consult your local distributor for fireplace code information.

LENNOX
HEARTH PRODUCTS