

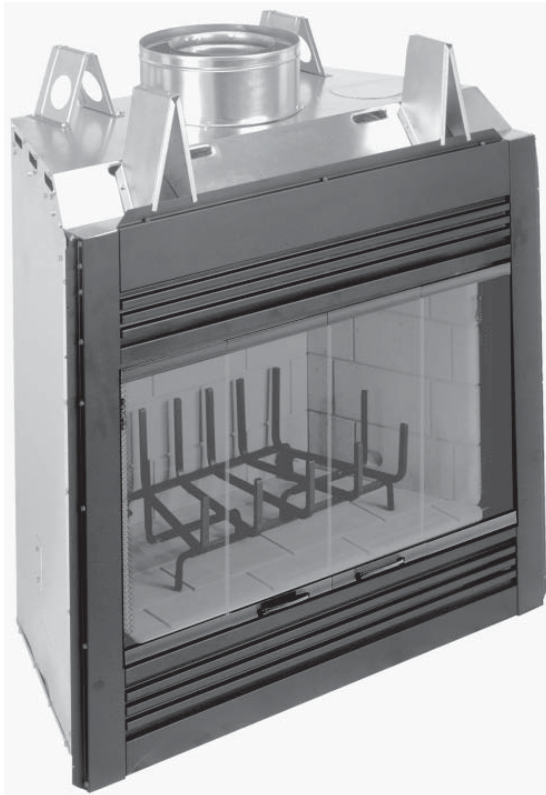

# INSTALLATION INSTRUCTIONS

## WOOD BURNING FIREPLACES MODEL HCD36MH



36" Wood Burning Fireplaces  
P/N 700,035M REV. A 03/2006

### MODELS

#### HCD36MH

This installation manual will enable you to obtain a safe, efficient and dependable installation of your fireplace system. Please read and understand these instructions before beginning your installation.

Do not alter or modify the fireplace or its components under any circumstances. Any modification or alteration of the fireplace system, including but not limited to the fireplace, chimney components and accessories, may void the warranty, listings and approvals of this system and could result in an unsafe and potentially dangerous installation.

**IMPORTANT! TO ASSURE PROPER ALIGNMENT OF GLASS DOORS: INSTALL THIS FIREPLACE IN A SQUARE AND PLUMB CONDITION, USING SHIMS AS NECESSARY AT SIDES AND/OR BOTTOM.**

**RETAIN THESE INSTRUCTIONS  
FOR FUTURE REFERENCE**

NATIONAL  
FIREPLACE  
INSTITUTE



CERTIFIED  
[www.nficertified.org](http://www.nficertified.org)

We recommend that our woodburning hearth products be installed and serviced by professionals who are certified in the U.S. by the National Fireplace Institute® (NFI) as NFI Woodburning Specialists or who are certified in Canada by Wood Energy Technical Training (WETT).



WH Report No.  
J20051034-231

## TABLE OF CONTENTS

Safety Rules .....	Page 2
Tools and Building Supplies .....	Page 2
Precautions .....	Page 2
Introduction .....	Page 3
Clearances/Height Requirements .....	Page 3
Chimney System .....	Page 3
Assembly Outline .....	Page 4
Location of Fireplace .....	Page 4
Assembly Steps .....	Page 5
Preinstallation Notes .....	Page 5
Clearances .....	Page 5
Installing the Fireplace .....	Page 5
Fireplace and Framing Specifications .....	Page 7
Installing the Chimney System .....	Page 8
Ten Foot Rule Summary .....	Page 10
Chimney Component Calculations .....	Page 11
Special Offset Instructions .....	Page 11
Offset Calculations .....	Page 11
Offset Elevation Chart .....	Page 12
Vertical Elevation Chart .....	Page 13
Installing Offsets .....	Page 14
Offset & Return Elbow Assemblies .....	Page 14
Optional Equipment Considerations .....	Page 14
Combustion Air Kits .....	Page 15
Gas Line Connection .....	Page 15
Cold Climate Insulation .....	Page 15
Glass Doors .....	Page 16
Mantels and Trim .....	Page 16
Hearth Extensions/Wall Shields .....	Page 16
Fireplace Finishes .....	Page 18
Accessories And Components .....	Page 18

## PACKAGING

The assembled wood fireplace is packaged with:

- 1 - One envelope containing the literature package which consists of the homeowner's manual, installation instructions, warranty and combustion air cover (located in the firebox).
- 2 - One Combustion Air Kit
- 3 - One Set of Doors
- 4 - One Blower Kit (installed).
- 5 - One Variable Speed Control Rheostat located in the firebox (to be mounted on a wall in a convenient location).

**IMPORTANT: PLEASE READ AND UNDERSTAND THESE RULES TO FOLLOW FOR SAFETY.**

## SAFETY RULES:

### WARNING

**To avoid the risk of damaging fireplace materials and increasing the risk of fire, do not use the fireplace to cook or warm food.**

1. Before starting your fireplace installation, read these installation instructions carefully to be sure you understand them completely and in entirety. Failure to follow them could cause a fireplace malfunction resulting in serious injury and/or property damage.
2. Always check your local building codes. The installation must comply with all local, regional, state and national codes and regulations.
3. These fireplaces must be installed with Security Chimneys FTF8 (8" inside diameter) Chimney System only. These systems are intended for use in any application where a traditional masonry type fireplace would apply. The chimney system must always vent to the outside of the building.
4. To ensure a safe fireplace system and to prevent the build-up of soot and creosote, inspect and clean the fireplace and chimney prior to use and periodically during the heating season.
5. Burn approved fuels only as defined in the Homeowner's Care and Operation Manual.
6. DO NOT use charcoal or coal under any circumstances.
7. NEVER use gasoline, gasoline-type lantern fuel, kerosene, charcoal lighter fluid, or similar liquids to start or "freshen up" a fire in this fireplace. Keep any flammable liquids a safe distance from the fireplace.
8. NEVER leave children unattended when there is a fire burning in the fireplace.
9. Always keep flue damper open when heat is present in the fireplace.
10. Before servicing, allow the fireplace to cool. Always shut off any electricity or gas to the fireplace while working on it. This will prevent any possible electrical shock or burns.
11. This fireplace is not intended to heat an entire home or be used as a primary heat source. It is designed to ensure homeowner comfort by providing supplemental heat to the room.
12. Always ensure that adequate supply of replacement combustion air from the outside of the house is accessible to the fire to support normal combustion. Fireplaces consume large volumes of air during the normal combustion process.
  - In the event the home is tightly sealed with modern energy efficient features, the combustion air kit (provided) may not provide all the air required to support combustion.
  - The manufacturer is not responsible for any smoking or related problems that may result from the lack of adequate combustion air. It is the responsibility of the builder/contractor to ensure that adequate combustion air has been provided for the fireplace.
13. Always ensure that the air inlet to the fireplace is free from debris and any other obstructions that can block the entrance of air.
14. DO NOT use a fireplace insert or any other product not specified by Lennox for use with this fireplace. All gas log sets must be operated with the damper clamped open.

### WARNING

**This fireplace has not been tested with an unvented gas log set. To reduce risk of fire or injury, do not install an unvented gas log set into this fireplace.**

15. "Smoke free" operation is not warranted nor are we responsible for inadequate system draft caused by mechanical systems, general construction conditions, inadequate chimney heights, adverse wind conditions and/or unusual environmental factors or conditions beyond our control.
16. Never, under any circumstances, install a fireplace, chimney component or any accessories, that has visible or suspected physical damage as a result of handling or transportation. These items should be inspected by your distributor or qualified factory representative to ensure safe condition. When in doubt, consult your distributor.
17. For additional safety considerations and complete operating instructions, refer to the Care and Operation Manual provided with the fireplace.

## TOOLS AND BUILDING SUPPLIES NORMALLY REQUIRED

Tools	Supplies
Phillips screwdriver	Framing materials
Hammer	Wall finishing materials
Saw and/or sabersaw	Caulking materials
Level	(noncombustible)
Measuring tape	Fireplace surround and
Plumb line	hearth extension
Electric drill and bits	materials
Pliers	(noncombustible)
Square	

## PRECAUTIONS

*Note: These fireplace systems are not difficult to install. However, in the interest of safety, it is recommended that the installer be a qualified or certified "tradesman" familiar with commonly accepted fireplace installation and safety techniques as well as prevailing local codes.*

*The most important areas of concern dealing with the installation of factory-built fireplaces are clearances to combustible materials, proper assembly of component parts, height of the chimney system, the proper use of accessories supplied by the manufacturer and the techniques employed in using finishing materials applied to the wall surrounding the fireplace, hearth extensions and wall shields. Each of these topics will be covered in thorough detail throughout this manual. Please give each your special attention as you progress with your installation.*

NOTE: DIAGRAMS & ILLUSTRATIONS ARE NOT TO SCALE.

**INTRODUCTION**  
**General Information**

These fireplaces are conventional radiant heat fireplaces with standard grate, an outside combustion air kit and optional decorative glass doors. These models are designed as heat circulating fireplaces and are fitted with an air circulating blower and a wall-mount variable speed control rheostat.

A steel grate is also included to properly position the fire and limit the amount of fuel. **IF A REPLACEMENT GRATE IS NEEDED REPLACE THE GRATE WITH CAT. NO. 87L26 ONLY.**

**Note:** Illustrations shown reflect “typical” installations with nominal dimensions and are for design and framing reference only. Actual installations may vary due to individual design preferences. However, always maintain minimum clearances to combustible materials and do not violate any specific installation requirements.

These fireplaces have been tested and listed by Warnock Hersey (Report No. J20051034-231) to U.L. standard 127. These units are intended for installation in manufactured homes. These units may also be installed in buildings of conventional construction including commercial, providing all instructions provided herein are strictly adhered to.

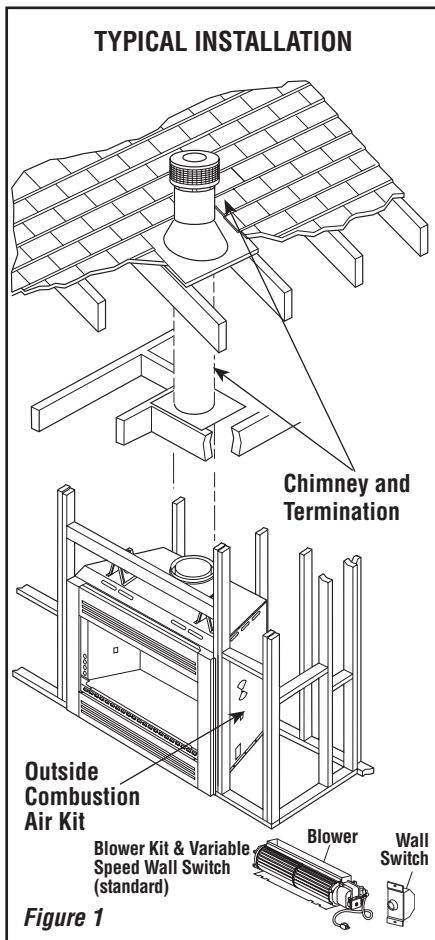

Figure 1

These fireplace systems are designed for installation in accordance with the National Fire Protection Standard for chimneys, fireplaces and solid fuel burning appliances; NFPA 211-latest edition and in accordance with codes such as the BOCA Basic/National Codes, the Standard Mechanical Code and the Uniform Building Codes.

**! WARNING**

**Failure to use manufacture provided parts, variations in techniques and construction materials or practices other than those described in this manual may create a fire hazard and void the limited warranty.**

**! WARNING**

**Do not pack or fill required air spaces with insulation or other material. No material is allowed in these areas. Secure the air-space around the chimney with the firestop/thimble before completing the installation. Maintain 2” clearance between chimney and thimble.**

**! WARNING**

**If insulation is used, the fireplace must not be placed directly against it. Insulation or vapor barriers, if used, must first be covered with gypsum board, plywood, particle board or other material to assure insulation and vapor barriers remain in place.**

When complete these fireplace systems consists of four basic “sub-systems”:

1. The Fireplace
2. The Chimney and Termination
3. Glass Doors
4. Combustion Air Kit

NOTE: DIAGRAMS & ILLUSTRATIONS ARE NOT TO SCALE.

**CLEARANCES AND HEIGHT REQUIREMENTS**

The fireplace may be placed on or near normal construction materials\*. The combustion air kit, firestop spacer and roof flashing (not chase flashings) may be placed directly on or against normal construction materials.\* The chimney requires a minimum 2” air space to combustibles and the fireplace outer wrapper requires a minimum 1” air space to combustibles. A combustible mantel may be installed 12” above the opening of the fireplace as per NFPA 211-latest edition.

The minimum installed height of the completed fireplace system is 10’ 6”. The maximum height is 40’ 0”. See the Chimney Height section on **Page 3** for more information.

The fireplace and chimney system must be enclosed when installed in or passing through a living area where combustibles or people may come in contact with it. This is important to prevent possible personal injury or fire hazard.

For questions, please call your distributor or the manufacturer. Special restrictions apply to the front and facing of the fireplace and nearby walls (See **Pages 16, 17 and 18**).

**CHIMNEY SYSTEM**

These fireplaces are designed and code listed for use with Security’s FTF8 chimney System only. Always use Security’s FTF8 chimney components with these fireplaces. Do not modify or alter these components as this may cause a potential serious hazard and void the Warranty.

**\*Construction Materials:**

- Framing Materials • Paneling
- Particle Board • Flooring
- Dry Wall • Plywood
- Noncombustible Insulating Materials
- Etc.

**Chimney Height**

The total height of your completed fireplace system from the surface the fireplace rests on to the chimney top must not exceed 40’ and must also meet minimum height requirements. Refer to the minimum system height chart.

Minimum System Height Security’s FTF8 Pipe	
Vertical Installation	10’ 6”
One Offsets	12’ 0”
Two Offsets	25’ 0”
<i>Table 1</i>	

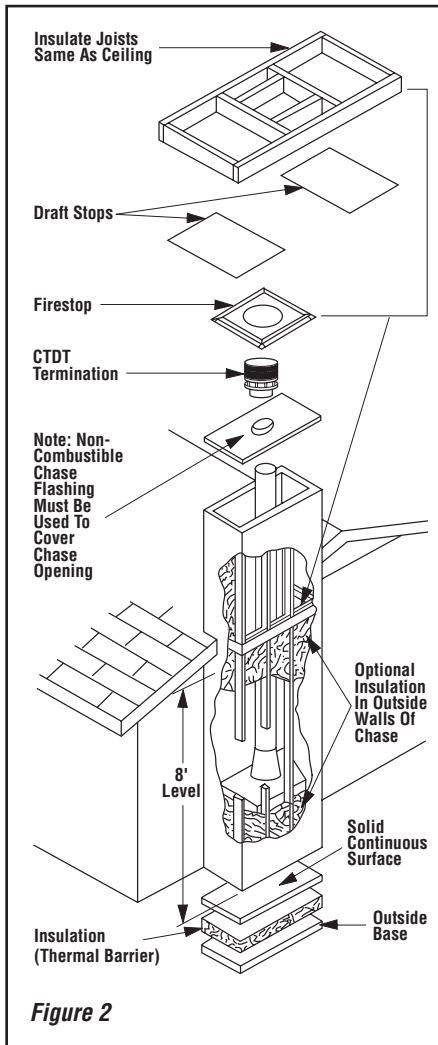

Figure 2

### Chimney Enclosure

Construct a box-like framed structure to enclose the fireplace and chimney within the confines of the manufactured home, not necessarily above the roof line.

As with all chimney installations, avoid overhead obstructions such as trees, power lines, etc. The chimney/fireplace enclosure should be constructed and insulated just like any outside wall. In a cold climate, we recommend the base of the chimney/fireplace enclosure should also be insulated between the solid continuous floor beneath the fireplace and the chase bottom. Insulation in a cold climate installation is not required for safety.

**Note:** Local codes may not require firestopping at the ceiling levels for outside chase installations. However, it is recommended for safety and the reduction of heat loss.

## ⚠ WARNING

**Do not obstruct the collar openings around the base of the chimney at the top of the fireplace. Never use blown insulation to fill the chimney enclosure.**

### ASSEMBLY OUTLINE Before You Start

Check your inventory list to be sure you have all the necessary parts supplied in good useable condition. Check also for any concealed damage.

Check the operation of the damper. The damper is controlled through the use of a control lever located within the firebox opening at the top center in front of the firebox lintel (Figure 3). The control lever snaps into place at either extreme of its range of motion. When locked in position all the way Down (to the front), the damper is open. When locked in position all the way Up (to the rear), the damper is closed.

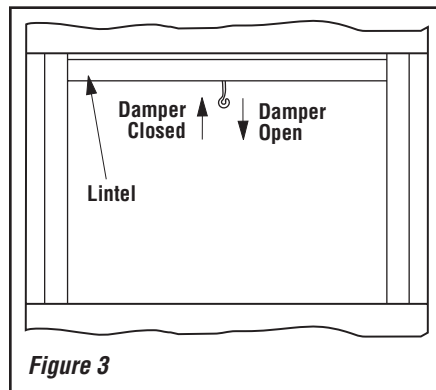

Figure 3

### LOCATION OF FIREPLACE

Carefully select the proper location for heat circulation, aesthetics, chimney obstructions and clearance to side wall(s). With proper pre-planning, a slight adjustment of a few inches can save considerable time and expense later during construction and assembly.

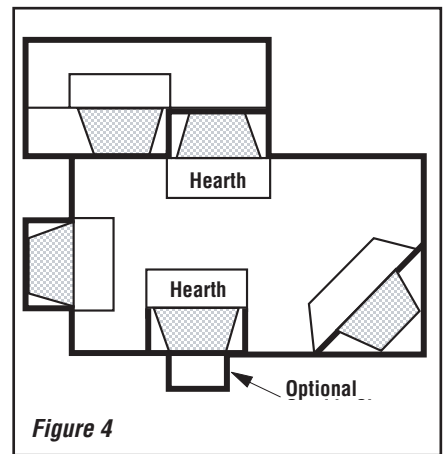

Figure 4

## ⚠ WARNING

**This fireplace and chimney system is not approved for use in a bedroom or any room used for sleeping.**

Carefully consider the position of the fireplace opening with respect to the location of adjacent or nearby stairwells, bath or kitchen exhaust fans and/or return air registers for forced air furnaces/air conditioners that could cause a smoking fireplace condition if the house is tightly insulated.

When locating the fireplace, consideration must be given to combustibles and final finishing. See Figure 5 and confine the final location of combustible finish materials to the "Safe Zone".

DO NOT permanently place furniture or other items such as decorative pillows within 60" of the fireplace front face.

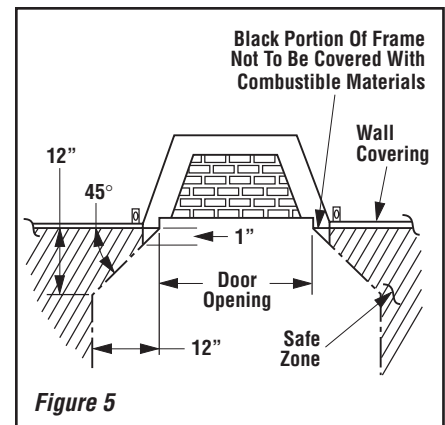

Figure 5

## Assembly Steps

**Note:** The following steps represent the normal sequence of installation. Each installation is unique, however, and might require a different sequence.

1. Position firebox prior to framing or into prepared framing.
2. Install the chimney system.
3. Connect house wiring to the fireplace for later connection to standard blower. The blower will also require connection to the (standard) wall-mount variable speed control rheostat.
4. Install optional outside combustion air kit.
5. Plumb gas line if a decorative gas appliance will be used. (Gas connections should only be performed by an experienced, licensed/certified tradesman).
6. Complete the installation, finish wall material, surround and hearth extension to your individual taste.

Study the three dimensional illustration (refer to **Figure 1**) to get a general idea of each element of your fireplace system.

## PRE-INSTALLATION NOTES

The fireplace may be installed directly on a combustible floor or raised on a platform of an appropriate height. Do not place fireplace on carpeting, vinyl or other soft floor coverings. It may, however, be placed on flat wood, plywood, particle board or other hard surfaces. Be sure fireplace rests on a solid continuous floor or platform with appropriate framing for support and so that no cold air can enter the room from under the fireplace.

The fireplace may be positioned and then the framing built around it, or the framing may be constructed and the fireplace positioned into the opening.

Usually, no special floor support is needed for the fireplace, however, to be certain:

1. Estimate the total weight of the fireplace system including chimney and surround materials such as brick, stone, etc., to be installed. Shipping weight for the fireplace may be found on **Page 7**.
2. Measure the square footage of the floor space to be occupied by the system, surrounds and hearth extensions.
3. Note the floor construction, i.e. 2 x 6's, 2 x 8's or 2 x 10's, single or double joists, type and thickness of floor boards.

## CAUTION

**Do not block the heat-circulating air inlet and outlet ports. Doing so may result in a potential fire hazard.**



## CAUTION

**The structural integrity of the manufactured home floor, wall, ceiling and roof must be maintained.**

The firestop thimble supplied with the unit must be used on a manufactured home installation. The firestop thimble must extend completely through the roof cavity to the outermost plane of the roof (See **Figures 16, 17 and 18**). Maintain 2" clearance between the thimble and the chimney.

If you plan to raise the fireplace and hearth extension, build the platform assembly then position fireplace and hearth extension on top. Secure the platform to the floor to prevent possible shifting.

## CLEARANCES

Minimum clearance to combustibles for the appliance is as follows: sides and back - 1" (25 mm), floor - 0" (0 mm), adjacent wall - 12" (305 mm), ceiling - 37-1/2" (953 mm).

## INSTALLING THE FIREPLACE

**IMPORTANT:** Plated polished brass glass doors may have a plastic covering over all brass pieces for protection during shipping and handling. The plastic covering should be removed after installation of the fireplace before its use. Under the plastic covering is a protective lacquer coating which should not be removed. In some instances, if it is removed, irreversible damage to the brass finish could occur.

- Step 1.** Slide the fireplace into prepared framing or position fireplace in its final position and frame later.

The fireplace may not be recessed into a combustible floor. Maintain the floor to hearth clearance established by the fireplace lower front face.

- Step 2.** Insert the provided metal safety strips, beneath the fireplace as illustrated (**Figures 6 through 9**). The safety strips should overlap 1/2" for continual coverage of the floor.

**Note:** Safety strips are not required when fireplace rests on a noncombustible surface.

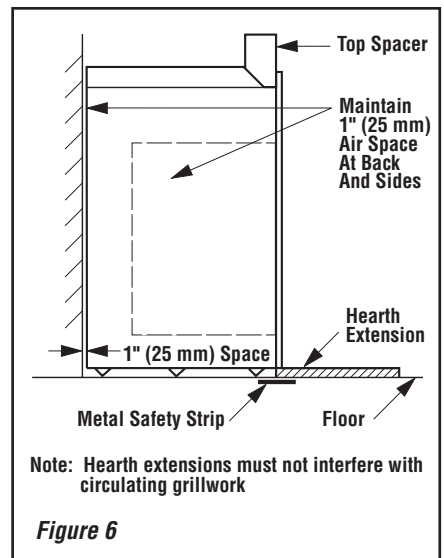

**Figure 6**

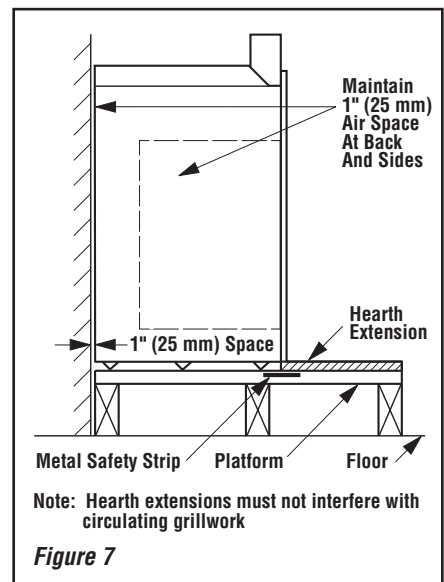
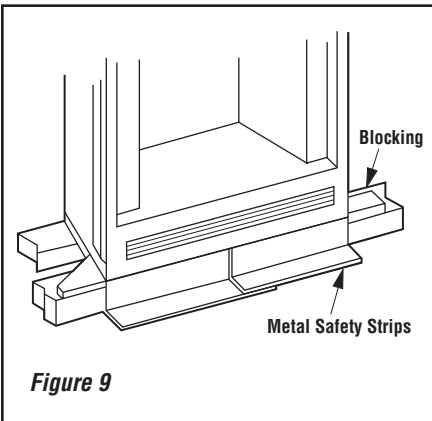
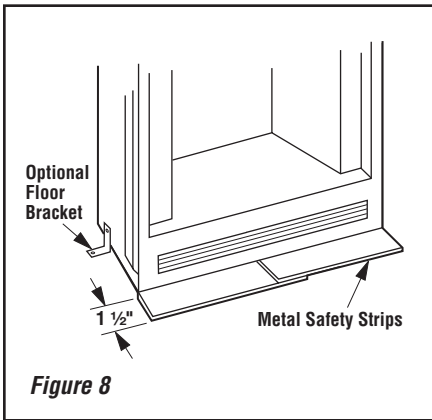

**Figure 7**

**Note:** Install the hearth extension only as illustrated (see **Pages 16, 17 and 18**).

The safety strips should extend from front of the fireplace at least 1-1/2" and should extend to be at least flush with the sides. In the event a wooden support is used to elevate the fireplace above the floor, a "Z" type safety strip should be fabricated and used to protect the front surface of the wood support as well as the floor beneath the hearth extension (**Figures 6 through 9**). The safety strips should be tacked down to prevent possible movement.

**Note:** The "Z" type safety strip is not supplied.



**Step 3.** Refer to fireplace drawings and specifications on **Page 7** for framing dimensions and details. Frame appliance enclosure as illustrated **on Page 7**.

**⚠ WARNING**

**Under no circumstances can the fireplace top spacers (see Figure 12) be removed or modified, nor may you notch the header to fit around or be installed lower than the spacers. The header may be in direct contact with the top spacers but may not be supported by them.**

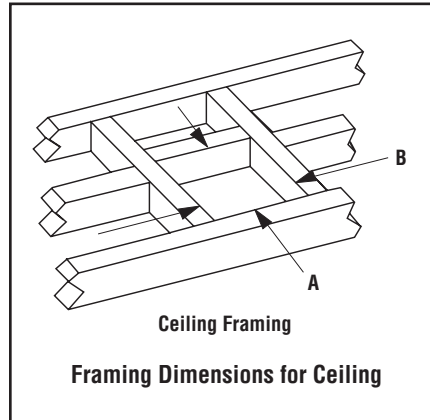

Framing Dimensions for Ceiling Inches (millimeters)		
Flue Type	A	B
FTF8, Vertical at 2" (51 mm)	16 1/2" (419 mm)	16 1/2" (419 mm)
FTF8 Offset 30° At 2" (51 mm)	16 1/2" (419 mm)	25" (635 mm)

**Figure 10**

**Note:** The framed depth, 21-3/4" (552 mm) from a framed wall, must always be measured from a finished surface. If a wall covering such as drywall is to be attached to the rear wall, then the 21-3/4" (552 mm) must be measured from the drywall surface. It is important that this dimension be exact.

If the appliance is to be elevated above floor level, a solid continuous platform must be constructed.

The header may rest on the top metal spacers, but must not be notched to fit around them.

Consult all local codes.

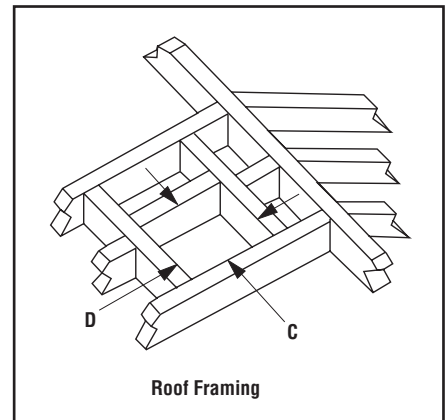

Framing Dimensions for Roof Inches		
Pitch	FTF8 at 2"	
	C	D*
0/12	16 1/2"	16 1/2"
6/12	16 1/2"	19"
12/12	16 1/2"	23 1/2"

\* Perpendicular to roof ridge

**Figure 11**

# FIREPLACE SPECIFICATIONS

Product Reference Information			
Cat. No.	Model	Ship. Weight	Ship. Volume
H4636	HCD36MH	175 lb.	26.72 cu. ft.

Framing Dimensions Fireplace Opening Width		
A		
A	43"	1092 mm
B	44-1/2"	1130 mm
C	29-1/2"	749 mm
D	15-3/4"	400 mm
E	73"	1854 mm
F	36-1/2"	927 mm
G	21-3/4"	552 mm
H	20-3/4"	527 mm
J	51-5/8"	1311 mm

Notes
Due to Lennox' ongoing commitment to quality, all specifications, ratings and dimensions are subject to change without notice.
⚠️All framing dimensions calculated for 1/2" dry wall at the fireplace face. If sheathing the chase or finishing with other thickness materials, calculations will need to be made.
See Page 6 for Ceiling and Roof Framing Dimensions
Diagrams & Illustrations Not to Scale



WH Report No.  
J20051034-231

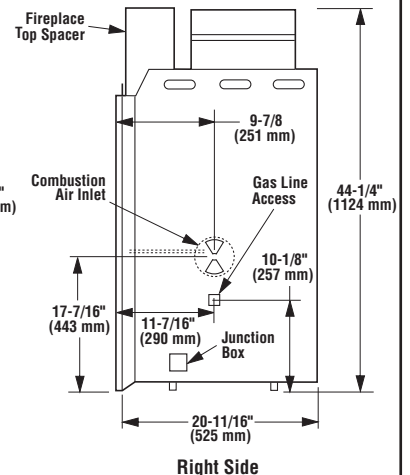
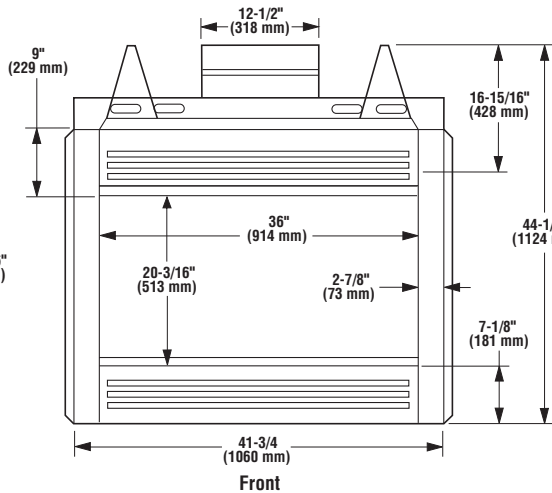
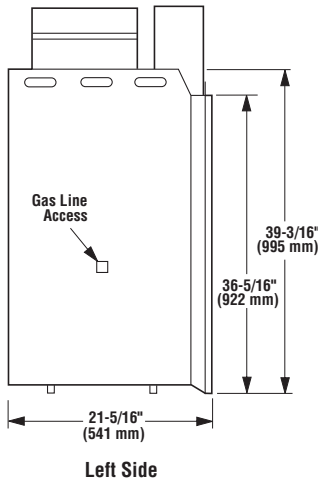
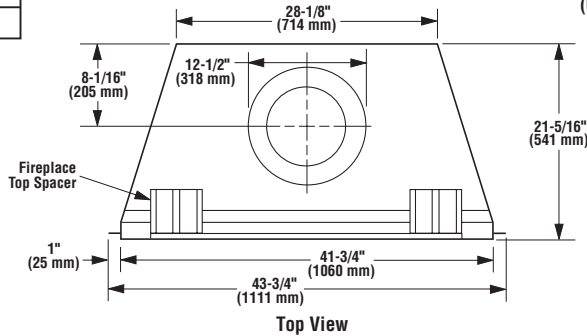
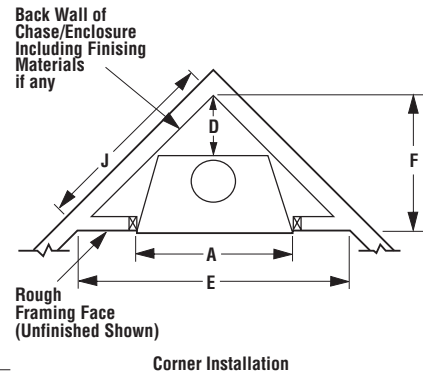
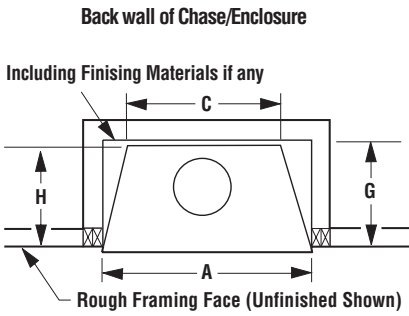
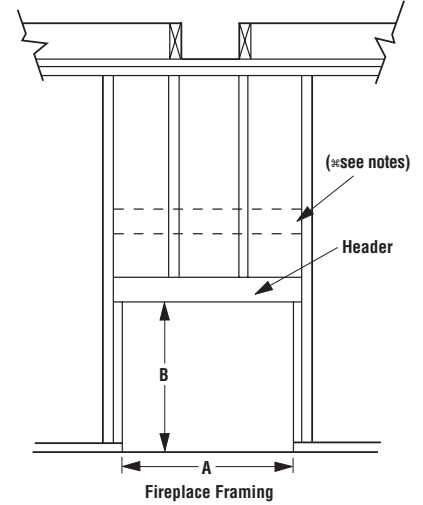
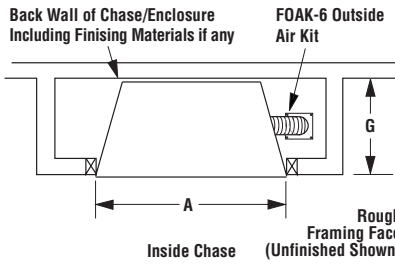
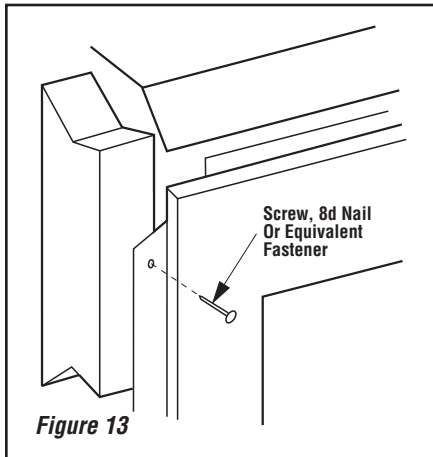

Figure 12

**Step 4.** Fireplace should be secured to side framing members using the full length nailing tabs at the top and bottom of the fireplace front face. Use screws, 8d nails or equivalent fasteners (**Figure 13**). This manufactured home model is also provided with floor brackets used to secure the fireplace to the floor to prevent shifting in transit.

**Note:** The use of floor brackets are optional. They are included (unbent) inside the Combustion Air Kit package, located inside the firebox. Refer to **Figure 8** for suggested bracket placement.



**Note:** The nailing tabs and the area directly behind the nailing tabs are exempt from the clearances described on **Page 5**. Maintain at least 1/2" clearance from the firebox wrapper to the framing at the closest point of contact, directly adjacent to the flange.

## INSTALLING THE CHIMNEY SYSTEM

**Step 1.** Before continuing, check the operation of the damper, as described on **Page 4**, (refer to **Figure 3**).

**Step 2.** Using standard construction framing techniques, construct opening for chimney route up through the ceiling(s) and roof or through an outside chase.

Framing must maintain adequate minimum air space clearance at all times.

### **CAUTION**

**Allow minimum 2" chimney air space to combustible framing members throughout vertical or offset chimney installation. A minimum 2" air space must be reserved for all combustible materials extending for any continuous length surrounding the chimney.**

Reference **Figures 10 and 11** and charts Framing Dimensions for Ceiling and Roof, which specify minimum ceiling and roof dimensions.

In new construction, to determine chimney center line, use plumb line from roof or ceiling above fireplace to center of flue collar on fireplace.

For remodeling, plumb to center of flue collar from ceiling above, drive nail through ceiling from below to mark position, then mark and cut to passage from above ceiling (around nail) (**Figure 14**). Then plumb from ceiling or roof level directly above hole which has just been completed.

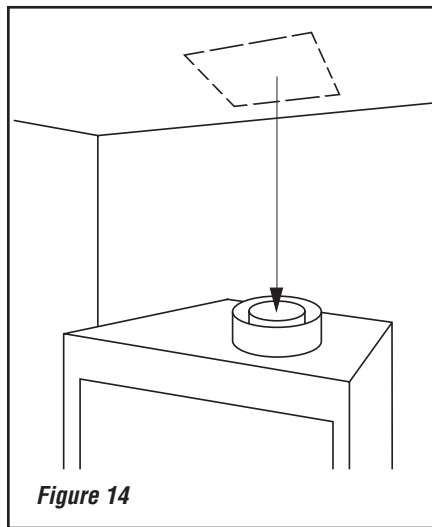

**Step 3.** Position appropriate thimble/firestop spacer combination at ceiling and nail temporarily with two (2) 8d nails or equivalent fasteners (see **Figures 16, 17 and 18**). Use one fastener on opposite sides to hold thimble/firestop spacer combination in position. Nail permanently, using at least two (2) more fasteners, after chimney sections have been assembled through the thimble/firestop spacer combination and after any necessary adjustments have been made. Firestop spacer must be secured by at least four (4) fasteners when completely installed.

**Note:** If there is a room above ceiling level, firestop spacer must be installed on the bottom side of the ceiling. If an attic is above ceiling level, firestop thimble must be installed on the bottom side of ceiling joist (**Figures 15 and 16**).

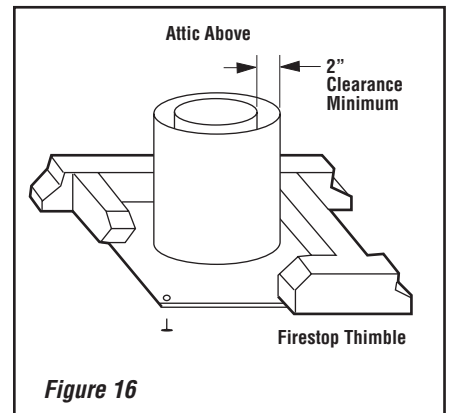
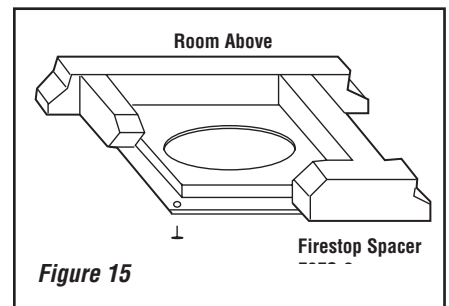

Ensure the thimble penetrates the roof opening. The thimble must extend completely through the ceiling or roof cavity to the outermost plane of the roof. Note: Thimble extensions (F8-TE26-2) are available from your distributor for constructions in which the distance between the outside of the roof and the inside of the ceiling exceeds 13". The thimbles and their extensions provide for zero clearances to combustibles and must be used at the ceiling/roof in manufactured homes (**Figures 17 and 18**).

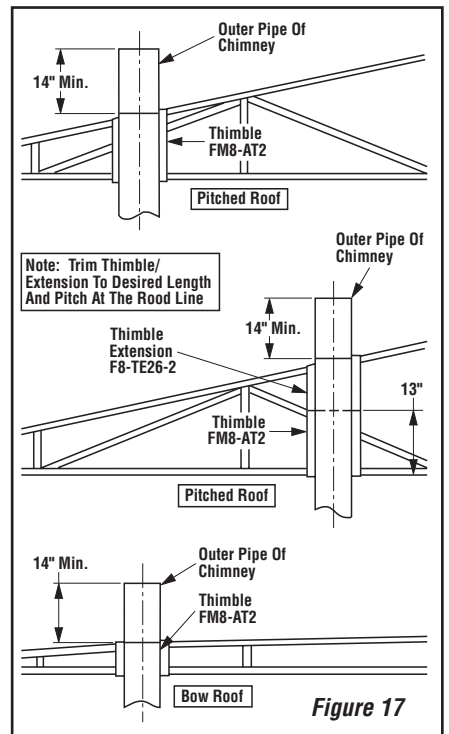

**! WARNING**

**Do not allow insulating materials to be blown into the space inside the thimble and the chimney. To do so could result in a fire hazard.**

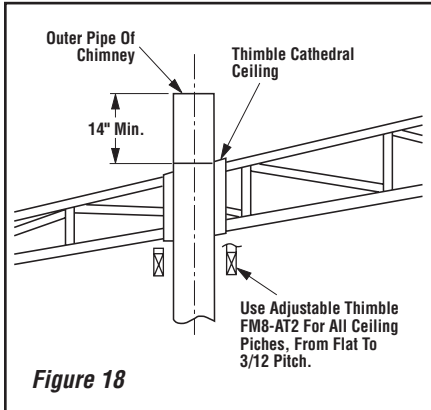

**Figure 18**

**Step 4. Note:** Chimney sections are constructed with a unique locking tab design, which ensures an immediate, tight assembly between sections. Plan your chimney requirements carefully before assembly as chimney is difficult to disassemble after installation. If disassembled, the tabs might become damaged. Be certain tabs are properly formed to ensure locking tabs engage properly.

The FTF8 chimney system is a two piece chimney, which snap together from the fireplace up. Start with the inner flue section with the lanced end up, snap lock it in to the matching collar on top of the fireplace. At all subsequent joints, the upper flue section fits into the preceding flue section. Each piece snaps together by means of locking tabs (9 locking tabs per joint). Check each piece by pulling up slightly from the top to ensure proper engagement before installing the next section. If the flue has been installed correctly, it will not separate when you test it. Also, the inner flue joint where each section is joined should be tight and flat without gaps (**Figure 19**).

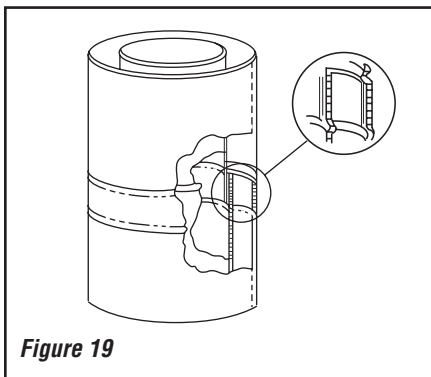

**Figure 19**

Outer pipe section installs in just the opposite way; the lanced end goes down and each new section goes OVER the outside of the previous section installed (**Figure 20**).

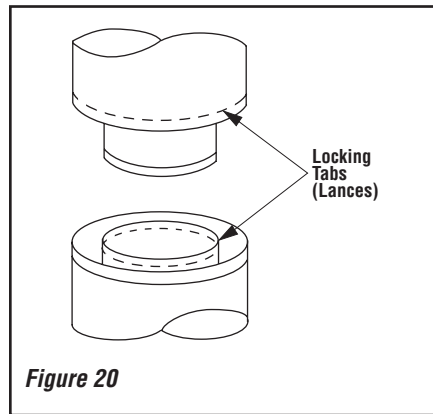

**Figure 20**

**Note:** Assemble one component of chimney at a time (inner section first, then outer section last) before proceeding with the next complete section.

Continue to assemble the chimney up through framed opening. Assemble just enough to penetrate the roof flashing openings (**Figure 21**). Maintain 2" minimum air space to insulation and building materials and always check each chimney joint (inner and outer) to ensure proper engagement. Check vertical alignment of chimney so that it projects from the roof in true vertical position.

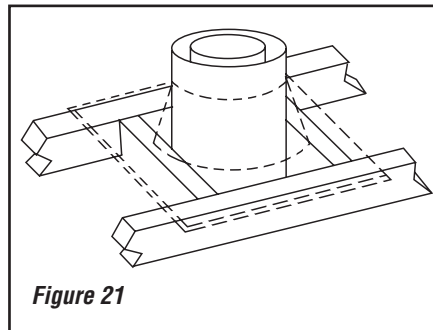

**Figure 21**

Security's chimney sections do not need to be screwed together. Additional reinforcement is not necessary except in certain offset conditions (refer to **Page 12, Figure 32**).

**Step 5.** The height of vertical chimney pipe supported only by the fireplace must not exceed 30'. Chimney heights above 30' must be supported by a Model FTF8-S4 stabilizer installed at 30' intervals.

**Note:** The Model FTF8-S4 adds 3" net effective height to the total chimney system.

Install the Model FTF8-S4 stabilizer by fitting inner section down into respective section of proceeding flue pipe and locking outer stabilizer section into place over the outer chimney pipe. Position for proper clearance through framed opening and nail straps securely (under tension in "shear") into place on framing. Use 8d nails. Attach successive lengths of chimney pipe directly to stabilizer using same techniques as described in **Step 4 (Figure 22)**.

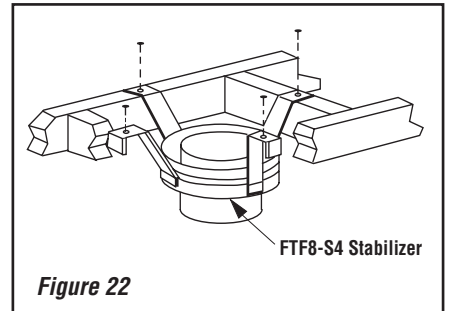

**Figure 22**

**Note:** Do not apply excessive pressure to any subsequent chimney sections following the stabilizer when installing. Ensure each subsequent chimney section is securely attached by testing as noted in **Step 4**.

**Step 6.** Select the proper Security Chimneys roof flashing based on pitch of roof. Use chart below for selection:

Roof Pitch	FTF8
Flat to 6/12	F8-F6
6/12 to 12/12	F8-F12

**Table 2**

Next, slide roof flashing over extended chimney section that previously has been installed above the roof opening in **Step 4**. Slide flashing all the way down until the flashing base rests flat on the roof (**Figure 23**). Again, check the vertical position of the chimney and the 2" minimum air space to combustibles.

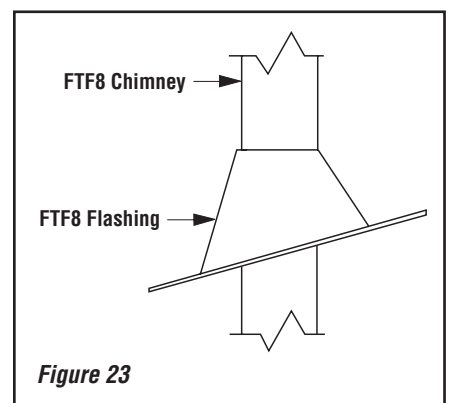

**Figure 23**

**Step 7.** Secure flashing by nailing along the perimeter into roof using 8d nails or equivalent fasteners. If shingled roof, slide upper end and sides of roof flashing under shingles (trim if necessary), seal the top and both sides of the flashing to the roof with roof caulking. Cover fastener heads with roof caulking (**Figure 24**).

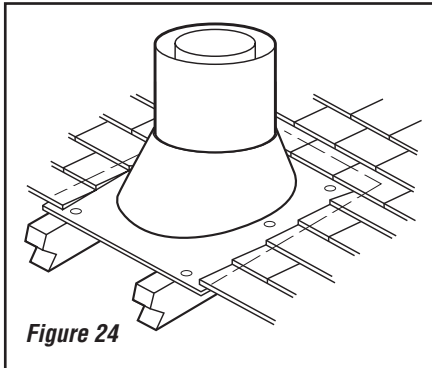

**Figure 24**

**Step 8.** The standard Security Chimneys FTF8 roof flashing assemblies include a storm collar. Slide the storm collar over outer chimney, rest on flashing spacers and align with top surface of flashing. Insert tab in slot, pull tight and bend tab back over slot. Seal storm collar to outer chimney with roof caulking or mastic around entire circumference of pipe. Also add extra roof caulking to the tab/slot area to seal completely against water penetration (**Figure 25**). Check all joints very carefully to ensure no water intrusion can take place.

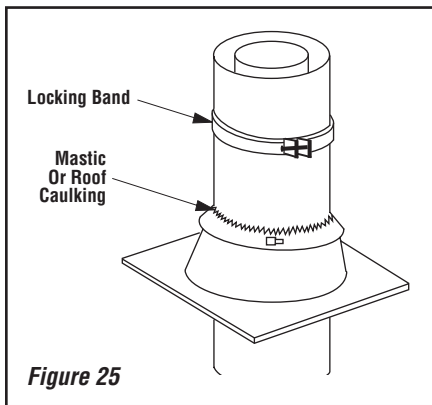

**Figure 25**

**Step 9.** FTF locking bands, Model FLB, may be required if the chimney extends too high above the roof flashing. As a general rule, if the chimney extends more than 6' above the roof flashing, the use of locking bands is advisable to strengthen the chimney assembly. Align the locking band at the chimney joint. Locking bands wrap around pipe joints equally covering the joints of both pipe sections. Use the nut provided and TIGHTEN snugly. Do not overtighten as this might damage the chimney section (refer to **Figure 24**).

**Note:** If chimney extends more than 8' above roof surface, guy wires are also recommended. Use three (3) guy wires, attach to locking band assembly, extend and secure to roof in a triangular pattern (**Figure 26**). Guy wires are not supplied by the manufacturer.

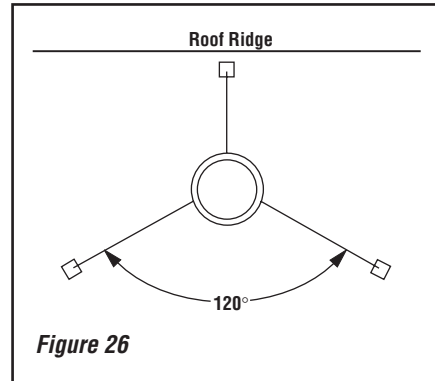

**Figure 26**

**Step 10. Using a CTD Termination:**

1. Hold the CTD over top of last chimney section (**Figure 27**).
2. Center inner slip section in inner flue pipe-slip down.

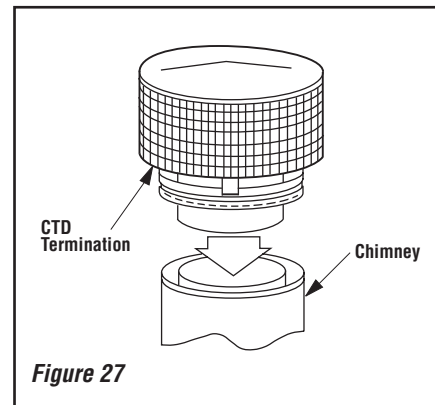

**Figure 27**

3. Center outer locking section over outer flue pipe. Push down until locking tabs are firmly engaged.
4. Pull up slightly on CTD to ensure locking joint has firmly engaged.

**Note:** It is recommended that all exterior exposed metal fireplace components; such as terminations, flashings, storm collars and/or flue be painted with a premium quality, high temperature, rust preventative paint designed for metal. This is especially important when installations are made in abnormally adverse or corrosive environments; such as near lakes, oceans or in areas with consistently high humidity conditions. Consult the paint manufacturers instructions for proper preparation and application.

### TEN FOOT RULE SUMMARY

The minimum chimney height above the roof and/or to adjacent walls and buildings is specified by all major building codes.

If the horizontal distance from the peak of the roof is less than 10', the top of the chimney must be at least 2' above the peak of the roof.

If the horizontal distance from the chimney edge to the peak of the roof is more than 10' a chimney height reference point is established on the roof surface 10' horizontally from the chimney edge. The top of the chimney must be at least 2' above this reference point. In all cases, the chimney cannot be less than 3' above the roof at the edge of the chimney.

The 2' in 10' rule is necessary in the interest of safety but does not ensure smoke-free operation. Trees, buildings, adjoining roof lines, adverse wind conditions, etc., may require a taller chimney should the fireplace not draft properly (**Figure 28**).

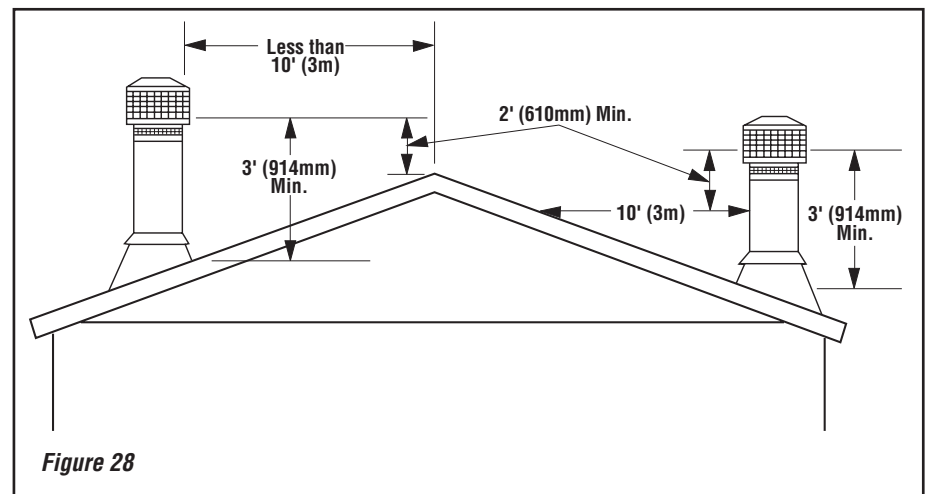

**Figure 28**

NOTE: DIAGRAMS & ILLUSTRATIONS ARE NOT TO SCALE.

## FTF8 CHIMNEY COMPONENT CALCULATIONS

The minimum installed height of the completed fireplace system is 10' 6". The maximum height is 40' 0" when the chimney is exposed.

To determine the number of chimney sections and chimney components required, follow these steps:

1. Determine total vertical height of the fireplace installation. This dimension is the distance from the surface the fireplace sets on to the point where smoke exits from the termination.
2. Determine the number of chimney components required, except chimney sections. This would include thimbles, extensions, roof flashing, etc.
3. The effective heights of the components are:

The Fireplace	=	44-1/4"
FTF8-12	=	10-1/4"
FTF8-18	=	16-1/4"
FTF8-24	=	22-1/4"
FTF8-36	=	34-1/4"
FTF8-48	=	46-1/4"
FTF8-CTD Termination	=	6"

4. Determine amount of chimney height required by subtracting total combined height of all pre-selected components (fireplace and chimney components from total desired height).

Reference Vertical Elevation Chart and determine the number of chimney sections (quantity and length) required See **Table 4 on Page 13**.

## SPECIAL OFFSET INSTRUCTIONS

### Chimney 30° Offset through Floor or Ceiling

It may be necessary to assemble the chimney at 30° when passing through the floor or ceiling area. Use the F8FS30-2 firestop spacer as shown in **Figure 29**. Support the chimney at floor or ceiling penetration with a FTF8 stabilizer if distance of chimney below ceiling is 10' or more. Maintain 2" minimum air space to combustibles from chimney sections.

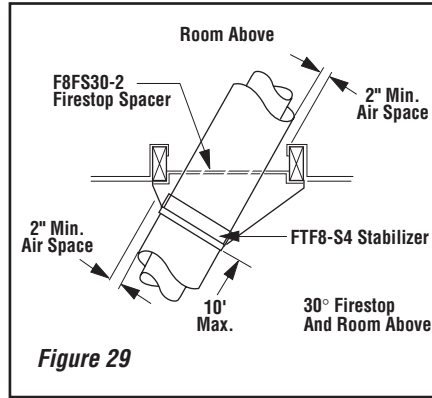

To clear any overhead obstructions, you may offset your chimney system using Security's 30° offset and return elbows. Use two elbows, an offset elbow to initiate the offset and a return elbow to terminate it. A 30° offset elbow, angling in any direction, may be the first component used off the top of the fireplace flue collar.

The offset and return elbows may be attached together, or a section or sections of chimney may be used between, but do not exceed 20' in total length between elbows. If sections of pipe exceed 10' between elbows, a chimney stabilizer must be used at the midpoint (see **Figure 30**). The stabilizer support straps must be attached under tension (in shear) to structural framing members above. When two sets of elbows are used, the maximum combined length of chimney used between elbows cannot exceed 20' (see **Figures 30 and 31**). Example: If C1 = 10' then C2 cannot exceed 10'.

If an offset exceeds 6' in length, each chimney joint beyond the first 6' of offset to the return elbow, must be secured by a No. 8 x 1/2" sheet metal screw located at the underside of the joint (see **Figure 33**).

A 1/8" diameter hole must be drilled in the chimney joint using a 1/8" diameter drill. Hole should be drilled in center of joint overlap (see **Figure 32**). Be sure to drill only through the outer chimney casting. Do not puncture the inner flue.

Maximum offset of chimney system is 30°. Two offsets must not be assembled to form a 60° offset. However, two sets of offset and return elbows may be used on a single flue system, provided the total height of the system exceeds 25'.

Return elbow support straps must be securely attached under tension (in shear) to structural framing members above. Do not substitute a FTF8-30 offset elbow in place of a FTF8-E30 return elbow.

## OFFSET CALCULATIONS

**Step 1.** Use Offset Chart to determine amount of horizontal offset (A) and height (B) for various chimney section assemblies.

**Step 2.** Use "Height of Chimney Only" column in The Vertical Elevation Chart to determine combinations of chimney used above return elbow to achieve desired heights. Reference Components Effective Height Chart in vertical elevation chart section.

**Step 3.** Use Elevation Chart as job estimator only. Add necessary firestop spacers and stabilizers as required. Firestop spacers must be used as shown in **Figure 15** and stabilizers as shown in **Figure 22**.

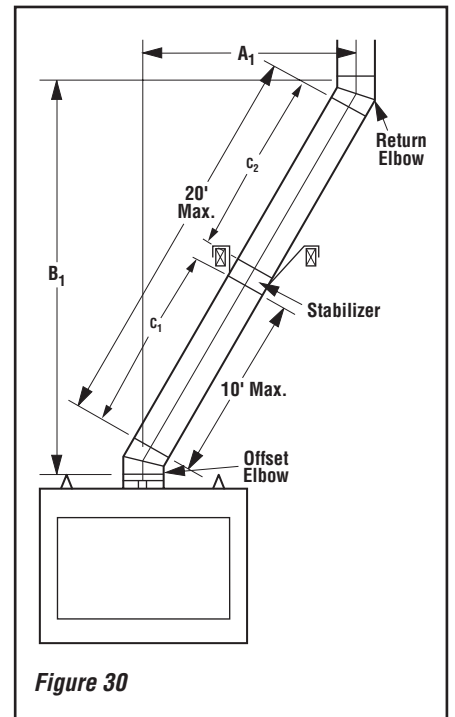

## FTF8 OFFSET ELEVATION CHART

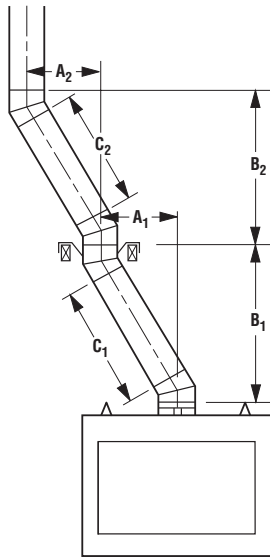
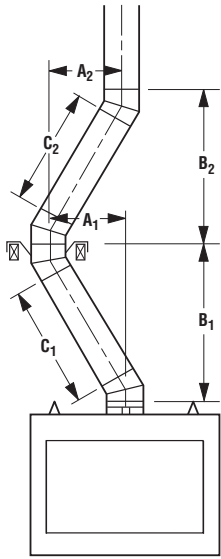

**Figure 31**

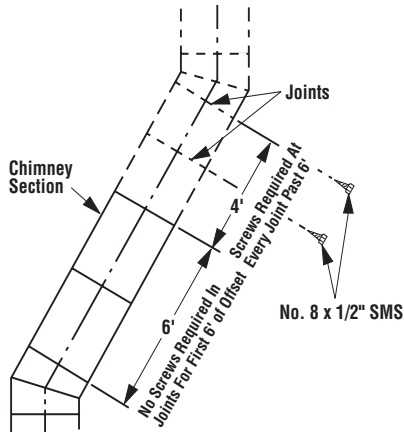

**Figure 32**

A Offset (Inches)	B Height (Inches)	FTF8-S4 Stabilizer	Number of FTF8 Chimney Sections					A Offset (meters)	B Height (meters)
			12"	18"	24"	36"	48"		
4	15 3/4	-	0	0	0	0	0	0.10	0.40
9 1/8	24 5/8	-	1	0	0	0	0	0.23	0.63
12 1/8	29 3/4	-	0	1	0	0	0	0.31	0.76
14 1/4	33 1/2	-	2	0	0	0	0	0.36	0.85
15 1/8	35	-	0	0	1	0	0	0.38	0.89
17 1/4	38 5/8	-	1	1	0	0	0	0.44	0.98
20 1/4	43 7/8	-	0	2	0	0	0	0.51	1.11
21 1/8	45 3/8	-	0	0	0	1	0	0.54	1.15
22 3/8	47 1/2	-	2	1	0	0	0	0.57	1.21
23 1/4	49	-	0	1	1	0	0	0.59	1.25
25 3/8	52 3/4	-	1	2	0	0	0	0.64	1.34
27 1/8	55 3/4	-	0	0	0	0	1	0.69	1.42
28 3/8	57 7/8	-	1	1	1	0	0	0.72	1.47
29 1/4	59 3/8	-	0	1	0	1	0	0.74	1.51
31 3/8	63 1/8	-	0	2	1	0	0	0.80	1.60
32 1/4	64 5/8	-	0	0	1	1	0	0.82	1.64
33 1/2	66 3/4	-	2	1	1	0	0	0.85	1.70
35 1/4	69 7/8	-	0	1	0	0	1	0.90	1.77
36 1/2	72	-	2	0	2	0	0	0.93	1.83
38 1/4	75	-	0	0	0	2	0	0.97	1.91
40 3/8	78 3/4	-	0	1	1	1	0	1.03	2.00
42 1/2	82 3/8	-	0	2	2	0	0	1.08	2.09
44 1/4	85 3/8	-	0	0	0	1	1	1.12	2.17
46 3/8	89 1/8	-	0	1	0	2	0	1.18	2.26
50 1/4	95 3/4	-	0	0	0	0	2	1.28	2.43
52 3/8	99 1/2	-	0	1	0	1	1	1.33	2.53
55 3/8	104 5/8	-	0	0	1	1	1	1.41	2.66
58 3/8	109 7/8	-	0	1	0	0	2	1.48	2.79
61 3/8	115 1/8	-	0	0	0	2	1	1.56	2.92
63 1/2	118 3/4	-	0	1	1	1	1	1.61	3.02
68 7/8	128	1	0	0	0	1	2	1.75	3.25
71	131 3/4	1	0	1	0	2	1	1.80	3.35
74 7/8	138 1/2	1	0	0	0	0	3	1.90	3.52
77	142 1/8	1	0	1	0	1	2	1.96	3.61
80	147 3/8	1	0	0	1	1	2	2.03	3.74
83	152 1/2	1	0	1	0	0	3	2.11	3.88
86	157 3/4	1	0	0	0	2	2	2.18	4.01
88 1/8	161 3/8	1	0	1	1	1	2	2.24	4.10
92	168 1/8	1	0	0	0	1	3	2.34	4.27
94 1/8	171 3/4	1	0	1	0	2	2	2.39	4.36
98	178 1/2	1	0	0	0	0	4	2.49	4.54
100 1/8	182 1/8	1	0	1	0	1	3	2.54	4.63
103 1/8	187 3/8	1	0	0	1	1	3	2.62	4.76
106 1/8	192 5/8	1	0	1	0	0	4	2.70	4.89
109 1/8	197 3/4	1	0	0	0	2	3	2.77	5.02
115 1/8	208 1/8	1	0	0	0	1	4	2.92	5.29
121 1/8	218 1/2	1	0	0	0	0	5	3.08	5.55

**Table 3**

NOTE: DIAGRAMS & ILLUSTRATIONS ARE NOT TO SCALE.

## FTF8 VERTICAL ELEVATION CHART

Height Of Chimney Only		Number Of FTF8 Chimney Components						Height Of Chimney Only	Height Of Chimney Only		Number Of FTF8 Chimney Components						Height Of Chimney Only
Inches	Feet/Inches	12"	18"	24"	36"	48"	-S4	Meters	Inches	Feet/Inches	12"	18"	24"	36"	48"	-S4	Meters
10 ¼	0 10 ¼	1	0	0	0	0	-	0.26	247 ½	20 7 ½	0	1	0	0	5	-	6.29
16 ¼	1 4 ¼	0	1	0	0	0	-	0.41	253 ½	21 1 ½	0	0	1	0	5	-	6.44
22 ¼	1 10 ¼	0	0	1	0	0	-	0.57	257 ¾	21 5 ¾	1	1	0	0	5	-	6.55
26 ½	2 2 ½	1	1	0	0	0	-	0.67	263 ¾	21 11 ¾	1	0	1	0	5	-	6.70
32 ½	2 8 ½	1	0	1	0	0	-	0.83	269 ¾	22 5 ¾	0	1	1	0	5	-	6.85
34 ¼	2 10 ¼	0	0	0	1	0	-	0.87	275 ¾	22 11 ¾	1	0	0	1	5	-	7.00
38 ½	3 2 ½	0	1	1	0	0	-	0.98	277 ½	23 1 ½	0	0	0	0	6	-	7.05
44 ½	3 8 ½	1	0	0	1	0	-	1.13	281 ¾	23 5 ¾	0	1	0	1	5	-	7.16
46 ¼	3 10 ¼	0	0	0	0	1	-	1.17	287 ¾	23 11 ¾	1	0	0	0	6	-	7.31
50 ½	4 2 ½	0	1	0	1	0	-	1.28	293 ¾	24 5 ¾	0	1	0	0	6	-	7.46
56 ½	4 8 ½	1	0	0	0	1	-	1.44	299 ¾	24 11 ¾	0	0	1	0	6	-	7.61
62 ½	5 2 ½	0	1	0	0	1	-	1.59	304	25 4	1	1	0	0	6	-	7.72
68 ½	5 8 ½	0	0	1	0	1	-	1.74	310	25 10	1	0	1	0	6	-	7.87
72 ¾	6 ¾	1	1	0	0	1	-	1.85	316	26 4	0	1	1	0	6	-	8.03
78 ¾	6 6 ¾	1	0	1	0	1	-	2.00	322	26 10	1	0	0	1	6	-	8.18
84 ¾	7 ¾	0	1	1	0	1	-	2.15	323 ¾	26 11 ¾	0	0	0	0	7	-	8.22
90 ¾	7 6 ¾	1	0	0	1	1	-	2.31	328	27 4	0	1	0	1	6	-	8.33
92 ½	7 8 ½	0	0	0	0	2	-	2.35	334	27 10	1	0	0	0	7	-	8.48
96 ¾	8 ¾	0	1	0	1	1	-	2.46	340	28 4	0	1	0	0	7	-	8.64
102 ¾	8 6 ¾	1	0	0	0	2	-	2.61	346	28 10	0	0	1	0	7	-	8.79
108 ¾	9 ¾	0	1	0	0	2	-	2.76	350 ¼	29 2 ¼	1	1	0	0	7	-	8.90
114 ¾	9 6 ¾	0	0	1	0	2	-	2.91	356 ¼	29 8 ¼	1	0	1	0	7	-	9.05
119	9 11	1	1	0	0	2	-	3.02	365 ¼	30 5 ¼	0	1	1	0	7	1	9.28
125	10 5	1	0	1	0	2	-	3.18	371 ¼	30 11 ¼	1	0	0	1	7	1	9.43
131	10 11	0	1	1	0	2	-	3.33	373	31 1	0	0	0	0	8	1	9.47
137	11 5	1	0	0	1	2	-	3.48	377 ¼	31 5 ¼	0	1	0	1	7	1	9.58
138 ¾	11 6 ¾	0	0	0	0	3	-	3.52	383 ¼	31 11 ¼	1	0	0	0	8	1	9.73
143	11 11	0	1	0	1	2	-	3.63	389 ¼	32 5 ¼	0	1	0	0	8	1	9.89
149	12 5	1	0	0	0	3	-	3.78	395 ¼	32 11 ¼	0	0	1	0	8	1	10.04
155	12 11	0	1	0	0	3	-	3.94	399 ½	33 3 ½	1	1	0	0	8	1	10.15
161	13 5	0	0	1	0	3	-	4.09	405 ½	33 9 ½	1	0	1	0	8	1	10.30
165 ¼	13 9 ¼	1	1	0	0	3	-	4.20	411 ½	34 3 ½	0	1	1	0	8	1	10.45
171 ¼	14 3 ¼	1	0	1	0	3	-	4.35	417 ½	34 9 ½	1	0	0	1	8	1	10.60
177 ¼	14 9 ¼	0	1	1	0	3	-	4.50	419 ¼	34 11 ¼	0	0	0	0	9	1	10.65
183 ¼	15 3 ¼	1	0	0	1	3	-	4.65	423 ½	35 3 ½	0	1	0	1	8	1	10.76
185	15 5	0	0	0	0	4	-	4.70	429 ½	35 9 ½	1	0	0	0	9	1	10.91
189 ¼	15 9 ¼	0	1	0	1	3	-	4.81	435 ½	36 3 ½	0	1	0	0	9	1	11.06
195 ¼	16 3 ¼	1	0	0	0	4	-	4.96	441 ½	36 9 ½	0	0	1	0	9	1	11.21
201 ¼	16 9 ¼	0	1	0	0	4	-	5.11	445 ¾	37 1 ¾	1	1	0	0	9	1	11.32
207 ¼	17 3 ¼	0	0	1	0	4	-	5.26	451 ¾	37 7 ¾	1	0	1	0	9	1	11.47
211 ½	17 7 ½	1	1	0	0	4	-	5.37	457 ¾	38 1 ¾	0	1	1	0	9	1	11.63
217 ½	18 1 ½	1	0	1	0	4	-	5.52	463 ¾	38 7 ¾	1	0	0	1	9	1	11.78
223 ½	18 7 ½	0	1	1	0	4	-	5.68	465 ½	38 9 ½	0	0	0	0	10	1	11.82
229 ½	19 1 ½	1	0	0	1	4	-	5.83	469 ¾	39 1 ¾	0	1	0	1	9	1	11.93
231 ¼	19 3 ¼	0	0	0	0	5	-	5.87	475 ¾	39 7 ¾	1	0	0	0	10	1	12.08
235 ½	19 7 ½	0	1	0	1	4	-	5.98	481 ¾	40 1 ¾	0	1	0	0	10	1	12.24
241 ½	20 1 ½	1	0	0	0	5	-	6.13	486	40 6	1	0	1	1	9	1	12.34

**Table 4**

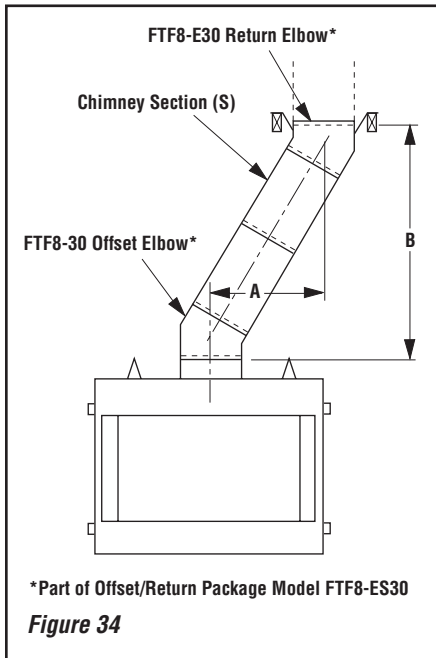
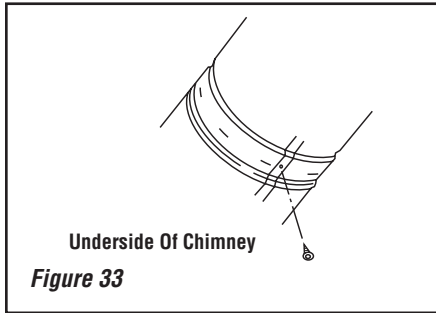

## INSTALLING OFFSETS

First, review the Offset Elevation Chart (Table 3) and Figure 34 for reference.

**Step 1.** Determine the offset distance where chimney is to pass through the first ceiling-dimension "A." To find this point on your ceiling, first determine the center point for a vertical chimney following the instructions for vertical installation.

Measure height to the ceiling from the top of fireplace-dimension "B." Use the appropriate Offset Elevation Chart to find dimension "A." Mark point where you will drive your nail to show the center point for your offset ceiling cut.

**Step 2.** Proceed by using the Straight Up Installation Instructions for cutting and framing ceiling and roof openings.

**Note:** See Framing and Dimension Chart for the sizes of the ceiling and roof openings. The size of the roof opening varies with the degree of pitch of the roof.

## Offset Elbow Assembly

Offset elbows install the same as chimney sections. First, snap the inner section INTO the preceding inner section of flue. Check connection by pulling up slightly to ensure a tight fit. Next, the outer sections snap lock OVER the preceding outer section of chimney. Again, check outer section by pulling up slightly to ensure proper connection is made.

## Return Elbow Assembly

Return elbows install the same way as round terminations and stabilizers:

- Step 1.** Hold return elbow over top of last chimney section.
- Step 2.** Center inner slip section into inner flue pipe-slip down.
- Step 3.** Center outer-locking section over outer chimney pipe. Push down until locking joint has firmly engaged.
- Step 4.** Pull up slightly on return elbow to ensure locking joint has firmly engaged.
- Step 5.** Secure support straps to framing members by nailing under tension in shear (Figure 35).

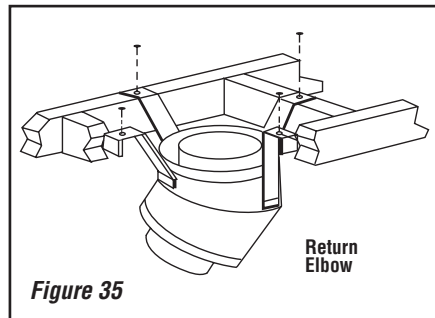

### Notes:

- The return elbow assembly performs the same function as a stabilizer. Consider this when determining the need for a stabilizer.
- Do not apply excessive pressure to any subsequent chimney section following return elbow assembly when installing. Ensure that each subsequent chimney section is securely attached by testing as noted above.

## BLOWER & OPTIONAL EQUIPMENT CONSIDERATIONS

### Blower Kit

A Blower kit model FBK-200 is installed as a standard component on these models. The wall-mount variable speed control rheostat (provided) should be installed on a wall in a convenient location.

**Note:** An optional ON/OFF wall switch (which provides single speed operation) can be installed in place of the standard variable speed control rheostat.

NOTE: DIAGRAMS & ILLUSTRATIONS ARE NOT TO SCALE.

## ! IMPORTANT

The fireplace must be wired to the house electrical system at the time of installation in order for the fans to operate, (See Figures 36 and 37).

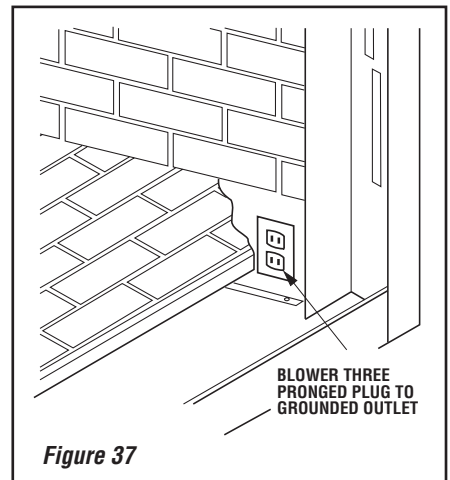
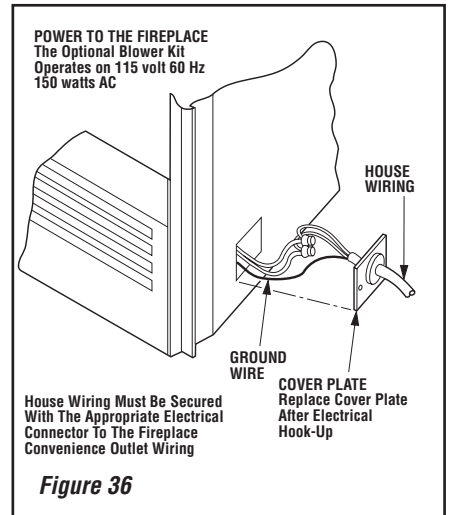

**Note:** The utilization of fans will increase the air flow around the firebox. However, only a minimal increase in heat output should be anticipated.

## ! IMPORTANT

This fireplace is not intended to be used as a substitute for a furnace to heat an entire home. Use for supplementary heating only.

The FBK-200 Blower Kit is design certified by Warnock Hersey for use with these appliances.

Always check local building codes. Electrical connections to the standard Blower Kit and Wall-Mounted Switch must comply with local regulations as well as the National Electric Code.

### Combustion Air Kits

These appliances are equipped with an outside (make-up) air door and integral actuator arm and an outside air kit with a collar, duct and hood (19M17). The appliance must be installed with an outside air vent system (**Figure 38**). These kits come complete with detailed installation instructions and all components necessary in completing a combustion air vent system.

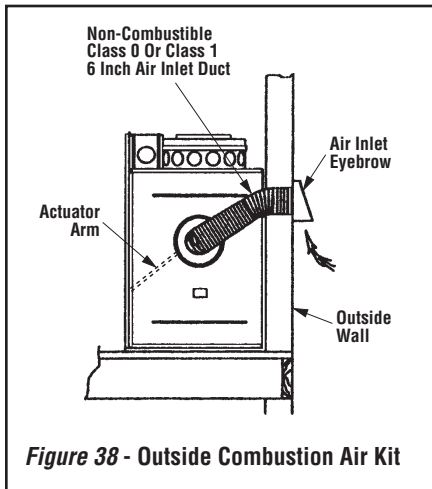

**Figure 38 - Outside Combustion Air Kit**

After completing the installation of the combustion air vent system the actuator arm must be put in service and tested to ensure proper operation before completing any enclosure around the firebox. Failure to do so may result in extensive and costly rework.

Locate the actuator arm along the right side of the appliance firebox opening and refer to **Figure 39**. To operate, push the end of the actuator to the left as shown in **Figure 39**, until it “pops” free of its “locked” position. Pull the actuator forward to open the combustion air door, and push it back to close. To “lock” the combustion air door closed, ensure the actuator is pushed all the way back then push the end of the actuators to the right until the step in the actuator moves behind the appliance front face within the slotted opening.

Operate the actuator through several cycles including the “lock position. Ensuring proper operation and freedom of movement. Return the actuator arm to the locked position.

### **! WARNING**

**This fireplace has not been tested with an unvented gas log set. To reduce risk of fire or injury, do not install an unvented gas log set into this fireplace.**

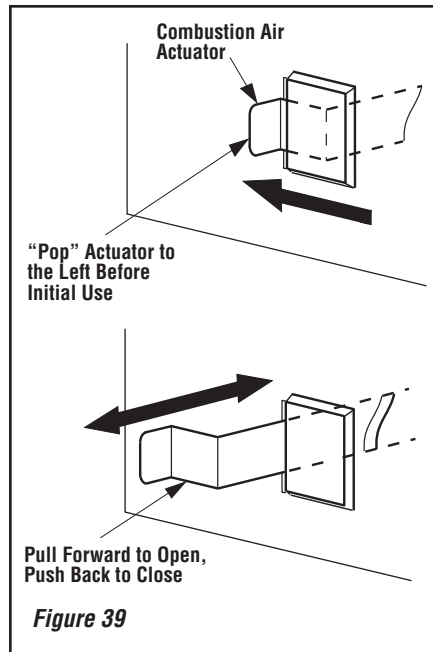

**Figure 39**

### Gas Line Connection

Install a 1/2” gas supply line through fireplace wall for connection to a decorative gas appliance inside the firebox. Outside, the gas supply line connects to a gas shut-off valve recessed flush into the wall or floor. The valve should be controlled by a removable valve key for safety.

Always plumb gas line installation per local codes. Check all connections using a gas leak test solution (also referred to as bubble leak solution). **Note:** Using a soapy water solution (50% dish soap, 50% water) is an effective leak test solution but it is not recommended, because the soap residue that is left on the pipes/fittings can result in corrosion over time. Never test any gas line connection with a match or open flame.

This provision is intended for connection to a decorative gas appliance incorporating an automatic shut-off device and complying with the Standard for Decorative Gas Appliances for installation in vented fireplaces, ANSI Z21.60 (1991) or American Gas Association draft requirements for Gas-Fired Log Lighters for Wood Burning Fireplaces, Draft No. 4 dated August, 1993. Install in accordance with the National Fuel Gas Code, ANSI Z223.1. This complies with the revised U.L. 127 standard.

### **! CAUTION**

**When using the decorative gas appliance, the fireplace damper must be set in the fully open position.**

NOTE: DIAGRAMS & ILLUSTRATIONS ARE NOT TO SCALE.

### **! CAUTION**

**Plumbing connections should only be performed by a qualified, licensed plumber. Main gas supply must be off when plumbing gas line to fireplace or performing service.**

If you’re installing a gas line, connect it before the fireplace is framed and enclosed in the finished wall. The gas knockout is determined by the indentation located at the bottom and slightly off center in the side refractories. **THE KNOCKOUT IS ALWAYS REMOVED FROM INSIDE THE FIREPLACE. DO NOT REMOVE THE KNOCKOUT UNLESS YOU ARE INSTALLING A GAS LINE.** If removal is attempted from the outer wrapper, side refractory damage may occur. With a medium-sized hammer, lightly tap the surface of the indentation. The refractory material is very thin in this area and is easily removed. Once a small hole has been made, continue tapping until you have reached sufficient diameter for the gas line to fit through. The entire knockout does not have to be removed. Remove insulation in the gas line channel.

### **! IMPORTANT**

**Repack insulation material in square hole around gas line, interior and exterior of fireplace, to seal.**

### COLD CLIMATE INSULATION

If you live in a cold climate, it is especially important to seal all cracks around the fireplace and wherever cold air could enter the room with noncombustible material. Surround material must be caulked where it meets the black metal facing of the fireplace to avoid cold air intrusion. Use noncombustible caulking material only on fireplace facing to seal. Also, the outside air inlet duct should be wrapped with noncombustible insulation to minimize the formation of condensation. Do not place insulation materials directly against the chimney sections.

**Note:** For chimney chase installations, a cold climate kit is available (order 63L62 model FTF8-CCK2-LD). See instructions provided with kit for installation details.

**Note:** 2” (51 mm) air space must be preserved for all materials extending for any continuous length adjacent to the chimney.

It is especially important to insulate between the studs of an outside chase cavity and under the floor if the floor is above ground level. Do not place insulation directly against the fireplace or chimney system.

**Note:** A 2" air space must be preserved for all combustible materials extending for any continuous length adjacent to the chimney.

It is especially important to insulate between the studs of an outside chase cavity and under the floor if the floor is above ground level. Do not place insulation directly against the fireplace or chimney system.

### Glass Doors

Glass doors have been installed on these fireplaces as standard equipment. Shipping and transit may have moved them out of alignment.

The doors are properly adjusted when the top door trim is in a straight, level line and the gap between the doors is even at the top and bottom. If adjustments are required, grasp the door handle and loosen the lower door pivot pin using a 3/8" open end wrench\*. Slide the door panel on the hinge pin until the gap between the upper door trim and upper frame is even. Retighten the lower door pivot pin\*. Repeat this procedure for the opposite door if needed (**Figure 40**).

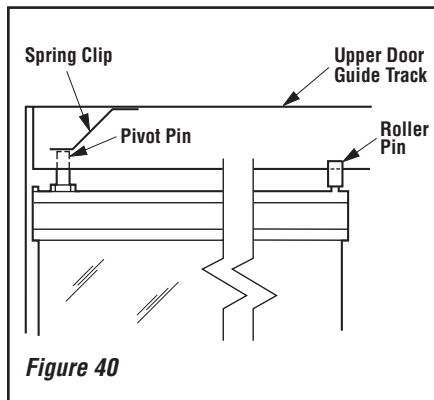

**\*Note:** Upper door pivot pins can also be loosened for adjustment purposes; however, it is easier to loosen lower pins.

## FIREPLACE FINISHES

### Mantels and Trim

It is sometimes best to frame your fireplace after it is positioned and the chimney is installed. Frame enclosure for chimney and fireplace with 2 x 4's (or heavier) lumber.

**Note:** The header may rest on the two (2) metal top spacers on top of the unit but the header must not be notched to fit around the spacers.

These fireplaces may sit directly on a combustible surface. A 2" air space is required between combustible framing and the chimney. A 1" air space is required between combustible framing and fireplace outer wrapper.

Combustible mantels and trim may be installed 12" above the fireplace opening as per NFPA 211-latest edition, and **Figure 41**. If a mantel is of a noncombustible material, it is exempt from these requirements as long as it does not interfere with the installation or operation of glass doors.

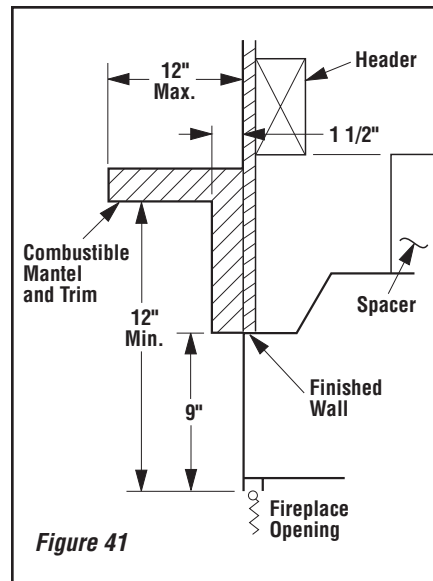

### Hearth Extensions and Wall Shields

A hearth extension must be installed with all fireplaces. Its purpose is twofold. It protects a combustible floor in front of the fireplace from both radiant heat and sparks and it distinguishes the prescribed hearth extension area from other non-protected surfaces.

The hearth extension must extend beyond the front and both sides of the HCD36MH fireplace side openings. Use a hearth extension constructed of a durable noncombustible material having an equal or better (lower k value) insulating value of  $k = .84 \text{ BTU/IN/FT}^2 \text{ HR } ^\circ\text{F}$  or a thermal resistance that equals or exceeds  $r = 1.19 \text{ HR } ^\circ\text{F FT}^2/\text{BTU IN}$ . With these values, determine the minimum thickness/material required using the formula and **Table 5** on **Page 17**.

If the fireplace is installed on a combustible floor, use the metal safety strips (provided) on the floor extending half under the fireplace and half under the hearth extension (refer to **Figures 6 and 7**).

If there is a continuous perpendicular side wall closer than 12" (305 mm) from the fireplace opening, it must be protected with a using a 24" x 30" x 1/2" (610 mm x 762 mm x 13 mm) wall shield (see **Figure 42**) constructed of a durable, noncombustible material having an equal or better (lower k value) insulating value than  $k = .54 \text{ BTU/IN FT}^2 \text{ HR } ^\circ\text{F}$ . A continuous protected side wall can not be closer than 7" (178 mm) from the side of the fireplace opening.

Secure the hearth extension to the floor to prevent possible shifting.

If fireplace is installed diagonally across a 90° corner; no wall shields are required.

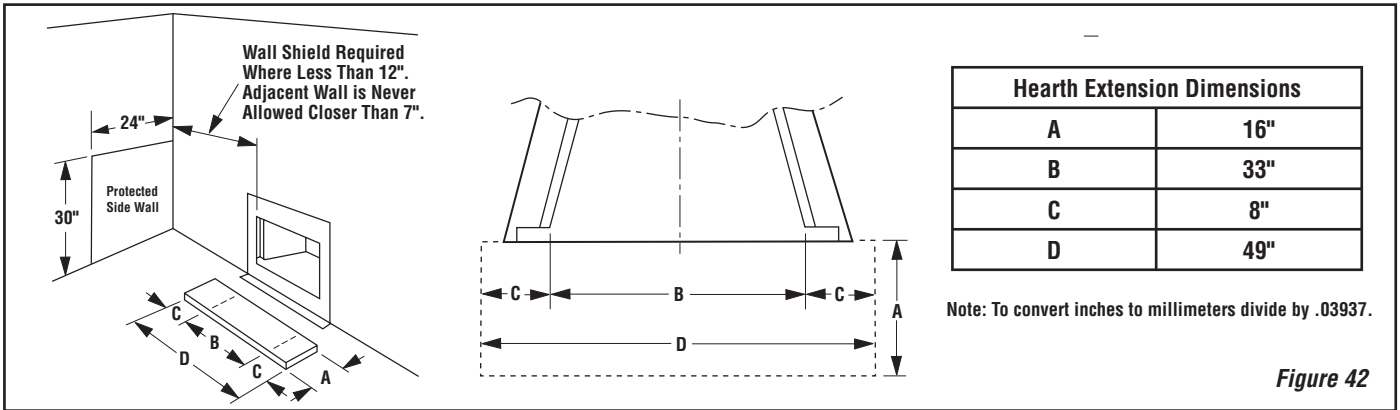

**Methods of Determining Hearth Extension and Wall Shield Equivalents** - To determine the thickness required for the alternate material when either the "k" value or "r" value is known, use either the **k formula** or **r formula**.

**Example:** If Micore 160 is to be used for the hearth extension fireplace, how thick must this material be?

- $k_M$  = k value per inch of **alternate** material
- $r_M$  = r value per inch of **alternate** material
- $T_M$  = minimum thickness required for **alternate** material
- $T_S$  = standard thickness of the **alternate** material
- $k_L$  = k value per inch of **listed** material
- $r_L$  = r value per inch of **listed** material
- $T_L$  = minimum thickness of **listed** material

**Note:** An asterix "\*" indicates, it is a value taken from **Table 5**.  
**Using the k formula:**

Minimum thickness of alternate material ( $T_M$ )	=	$\frac{k\text{-value (per Inch) of alternate material } (k_M)}{k\text{-value (per inch) of listed material } (k_L)}$	x	Specified min. thickness of listed material ( $T_L$ )
$T_M$ (inches)	=	$\frac{.84}{*.84}$	x	$T_L$
$T_M$ (inches)	=	$\frac{*.35}{*.84}$	x	.625"
.260 (inches)	=	.416	x	.625"

**Answer** - The minimum required thickness of the Micore 160 is .260," therefore round to nearest standard thickness available which is 1/4."

**Using the r formula:**

Minimum thickness of alternate material	=	$\frac{r\text{-value (per Inch) of listed material}}{r\text{-value (per inch) of alternate material}}$	x	Specified min. thickness of listed material
$T_M$ (inches)	=	$\frac{r_L}{r_M}$	x	$T_L$
$T_M$ (inches)	=	$\frac{*1.19}{*2.86}$	x	.625"
.417 (inches)=	=	.416	x	.625"

**Answer** - The minimum required thickness of the Micore 160 is .260," therefore round to nearest standard thickness available which is 1/4."

Listed Material			
	k (per inch)	r (per inch)	Listed Min. Thickness
Listed Material	.84 $k_L$	1.19 $r_L$	.656" (5/8") $T_L$
** Approved Alternate Materials for Floor/Hearth Protection			
Alternative Materials	Thermal Values		Minimum Thickness (rounded to nearest 1/8 inch)
	k (per inch) $k_M$	r (per inch) $r_M$	Min. Thickness $T_M$
Kaowool M Board	.47	2.13	.37" (3/8")
Micore 160™ U.S. Gypsum	.35	2.86	.27" (1/4")
Micore 300™ U.S. Gypsum	.46	2.17	.36" (3/8")
Durock™ Cement Board U.S. Gypsum	1.92	.52	1.50" (1-1/2")
Hardibacker™	1.95	.51	1.52" (1-1/2")
Hardibacker 500™	2.30	.43	1.80" (1-3/4")
Cultered Stone Hearth-stone™	2.82	.35	2.20" (2-1/4")
Wonderboard	3.23	.31	2.52" (2-1/2")
Super Firetemp M Johns-Manville	.61	1.64	.48" (1/2")
Super Firetemp L Johns-Manville	.54	1.85	.42" (3/8")
Face brick	9.00	.11	7.03" (7")
Common brick	5.00	.20	3.90" (3-7/8")
Cement mortar	5.00	.20	3.90" (3-7/8")
Ceramic tile	12.5	.08	9.76" (9-3/4")
Marble	~11	~.09	8.59" (8-5/8")

**Table 5**

\*\* If the hearth extension material(s) that is intended to be used is NOT listed on Table 5, the material can still be used if the material(s) is noncombustible. However, the manufacturer of the material must provide either the listed k-value per inch or r-value per inch with listed thickness so that the minimum thickness required for the hearth can be calculated (per instructions on this Page and/or as specified in the NFI Certification manuals).

**Note:** Also see NFI (National Fireplace Institute) Certification Manuals showing other acceptable calculation methods and acceptable alternate materials which can be used.

## Calculating Minimum Thickness if Multiple Materials are Used

At times it is important to know what combination of materials are acceptable for use as floor protection. The "R values" are used to determine acceptable combinations of materials because "R values" are additive where r and k values are not.

"R value" =  $1/k$  = "r" x thickness of material used

**Example:** Given that the required "R value" for a suitable floor protector used must be equal to or greater than:

$$"R" = r_L \times T_L = 1.19 \times .625 = 0.74."$$

If it is desired to elevate a marble hearth extension to a level of 5" or more above the floor surface. What combination of noncombustible materials can be used to accomplish this?

If common brick is used so that the 3 1/2" dimension is the height, "R" for the common brick becomes:

$$"R"_{\text{brick}} = r_M \times T_S = 0.20 \times 3 \frac{1}{2} = .70$$

Using 1/2" of mortar to set the brick, "R" for the mortar is calculated as follows:

$$"R"_{\text{mortar}} = r_M \times T_S = 0.20 \times \frac{1}{2} = .10$$

Next, a 3/4" marble slab set in 1/2" mortar covers the brick, "R" for the marble and mortar becomes:

$$"R"_{\text{marble}} = r_M \times T_S = 0.09 \times \frac{3}{4} = .068$$

$$"R"_{\text{mortar}} = r_M \times T_S = 0.20 \times \frac{1}{2} = .10$$

The sum of all "R values" is:  $.70 + .10 + .068 + .10 = .968$

This would be an acceptable combination of material for the hearth extension since the total calculated "R value" of the materials used is higher than the required "R value" of 0.74." An additional layer of insulating materials will not be required.

**Note:** Also see NFI Certification Manuals for expanded explanation on calculating "R values" when multiple materials are used.

## WARNING

The crack between the fireplace and the hearth extension must be sealed with a noncombustible material.

## WARNING

When installing the hearth extension be careful not to block the heat-circulating air inlet grill on circulating models.

When installing hearth extension in front of a circulating fireplace model, the fireplace must be raised if height of hearth extension exceeds 2" above bottom of fireplace (Figure 43).

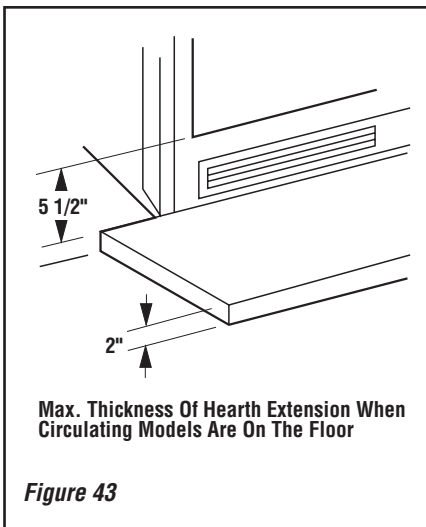

Figure 43

Secure the hearth extension to the floor to prevent possible shifting.

## FINISH TO YOUR TASTE

There are a wide variety of "finished looks" for these fireplaces, from formal wall decor with elaborate mantels to rustic wood paneling or warm brick facings.

Only noncombustible materials like stone, tile, brick, etc., may overlap the black front facing. Do not extend these materials beyond the black facing and into the firebox area. Be sure not to interfere with the installation and operation of glass doors or block the upper or lower grilles. Seal all joints between the black facing and wall surrounds to prevent air intrusion. Use noncombustible caulking material only to seal the black metal facing to the surround material on the finished wall.

Combustible materials may project beyond the sides of the fireplace opening as long as they are kept within the shaded areas illustrated in Figure 44.

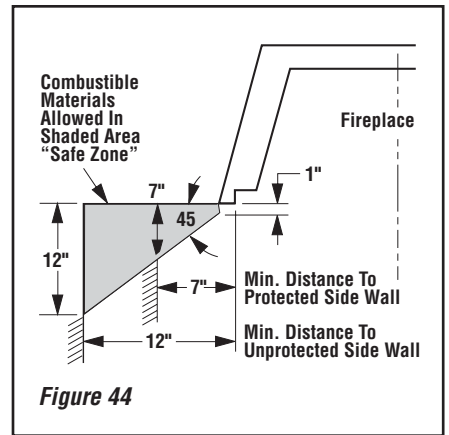

Figure 44

## ACCESSORY PARTS AND COMPONENTS LIST FOR MODEL HCD36MH

The accessory parts and components shown on Pages 18 through 20 are to be used only with your HCD-36MH fireplace system. Separate installation instructions are packaged with all combustion air kits and chimney terminations.

If you encounter any problems or have questions concerning the installation or application of this system, please contact your distributor. For the name of your nearest distributor call:

LHP  
1110 West Taft Avenue  
Orange, CA 92865

## INSTALLATION COMPONENTS

The following items are available for use in the installation of this appliance.

The variable speed control RHEOSTAT is included with FBK-200 models only

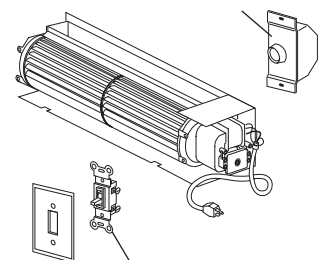

An ON/OFF WALL SWITCH can be used in place of the variable speed control RHEOSTAT (not supplied, order P/N 85L87 Wall Switch Kit)

Forced Air Blower Kits  
-Single Speed (blower only) 80L84 FBK-100  
-Variable Speed (blower & rheostat) 80L85 FBK-200

Note: The FBK-200 blower (installed) with wall mount variable speed rheostat is included as standard components for Model HCD36MH.

NOTE: DIAGRAMS & ILLUSTRATIONS ARE NOT TO SCALE.

## INSTALLATION COMPONENTS

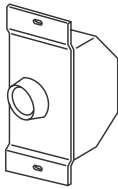

Variable Speed Control On/Off Wall Switch		
Cat. No.	Model No.	Description
045571H	VSWS	Variable Speed Wall Switch

### Variable Speed Wall Switch (standard component)

Provides variable speed control for blower kit (installed as standard component).

### ON/OFF Wall Switch Kit

This ON/OFF wall switch kit can be used in place of the standard variable speed wall switch. This switch provides single speed ON/OFF operation of the blower. Install the ON/OFF wall switch in a convenient location near the fireplace.

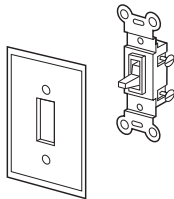

White Wall Switch Kit		
Cat. No.	Model No.	Description
85L87	FWSK	ON/OFF Wall Switch Kit

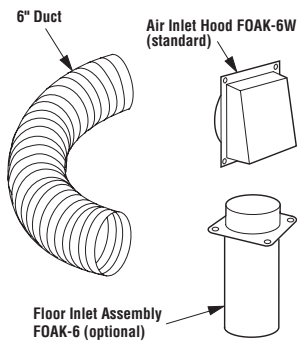

Outside Air Kit (optional)	19M17	FOAK-6W
Outside Air Kit (standard)	90L83	FOAK-6

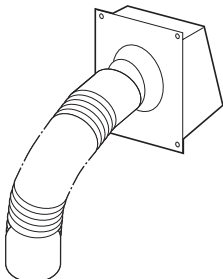

Ref. Form #750,082M

### Cold Climate Kit 63L 62 FTF8-CCK2-LD

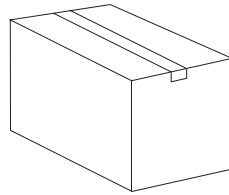

### Adjustable Chimney Pipe Kits H0560 FM8-PK20

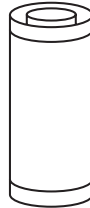

Chimney Section	63L10	FTF8-12
	63L13	FTF8-18
	H0522	FTF8-24
	63L14	FTF8-36
	63L15	FTF8-48

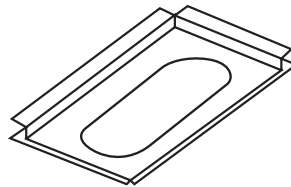

### Firestop Spacer (30°) 2" 63L32 F8FS30-2

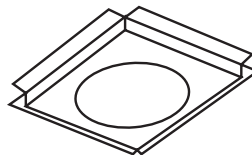

Firestop Spacer (Flat) (Single Pack)	63L31	F8FS-2
Firestop Spacer (Flat) (12 Pack)	94L76	F8FS-12

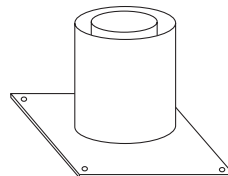

### Adjustable Firestop/Thimble H0326 FM8-AT2

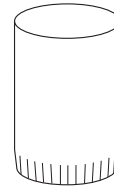

### Thimble Extension 2" 19M52 F8-TE26-2

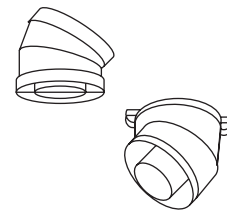

Offset/ Return Package		
30 Degree Offset/Return Elbow	FTF8-ES30	63L22
15 Degree Offset/Return Elbow	FTF8-OR15	63L28

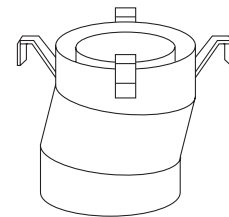

Ref. Form #750,012M

### Combination Offset/Return Elbow 63L28 FTF8-OR15

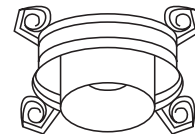

### Stabilizer 63L25 FTF8-S4

## ACCESSORIES AND COMPONENTS

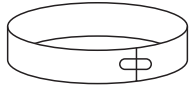

Ref. Form #750,080M

**Locking Band**                      **63L60**                      **FLB**

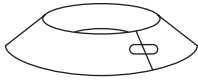

**Storm Collar**                      **63L59**                      **FSC**  
**Storm Collar (12 pack)**      **94L77**                      **FSC-B-12**

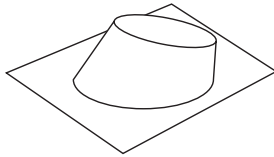

**Flashing**                      **19M55**                      **F8F6MH**  
   **19M56**                      **F8F12MH**  
   **63L38 (0-6/12)**              **F8F6**  
   **63L39 (6/12-12/12)**        **F8F12**

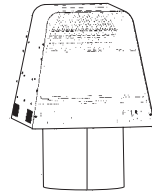

Ref. Form #750,036M

**Arch Type Termination**              **96L22**                      **FTF8-ATT**  
   **96L23**                      **FTF10-ATT**

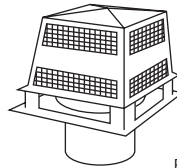

Ref. Form #750,015M

**Chase Termination - Pyramid (Square)**      **63L48**                      **FTF8-CT1**  
**Chase Termination - Pyramid, Black (Square)**      **91L79**                      **FTF8-CT1P**

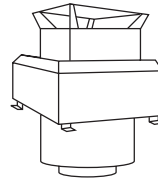

Ref. Form #750,016M

**Chase Termination (Square)**              **63L51**                      **FTF8-CT2**

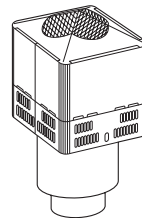

Ref. Form #750,077M

**Chase Termination**                      **96L20**                      **FTF8-CTT**  
   **96L21**                      **FTF10-CTT**

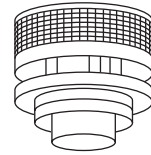

**Contemporary Termination - Round**              **63L42**                      **FTF8-CTD**  
**Contemporary Termination - Round, Black**      **H2238**                      **FTF8-CTDP**

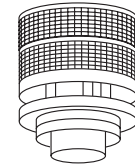

Ref. Form #750,205M

**Chase Termination (Round)**                      **H0203**                      **FTF8-CTDTM**

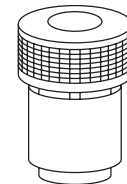

Ref. Form #750,014M

**Chase Termination (Round)**                      **63L45**                      **FTF8-CTDT**

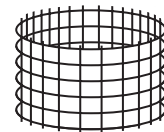

**Spark Arrestor (CT2 Termination)**              **63L57**                      **FSA-2**

The manufacturer reserves the right to make changes at any time, without notice, in design, materials, specifications, prices and also to discontinue colors, styles and products. Consult your local distributor for fireplace code information.