



HEARTH PRODUCTS

HEARTH PRODUCTS
KITS AND ACCESSORIES

750,194M
Rev. NC 10/2005

**CLOSED TOP ARCHED SHROUD
TERMINATION KIT**

**INSTALLATION INSTRUCTIONS FOR
CLOSED TOP SHROUD TERMINATION KITS**

CLOSED TOP ARCHED SHROUD TERMINATION KIT		
Item	Description	Quantity
1	Arch End Support, Shroud	2 ea.
2	Top Panel, Closed Shroud	2 ea.
3	Flashing Spacers	4 ea.
4	Instruction Sheet	1 ea.
5	Bag of Screws, 28 ea.	1 ea.

Table 1

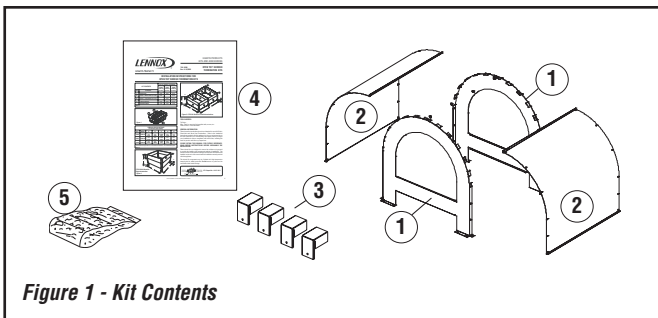

Figure 1 - Kit Contents

SHROUD SPECIFICATIONS Inches (millimeters)					
Cat. #	Model	A	*B	C	D
H1988	CTSA-33	34" (864)	5" (127)	34" (864)	34" (864)

**All shrouds must provide for air circulation at the base. Do not block this space.
Table 2*

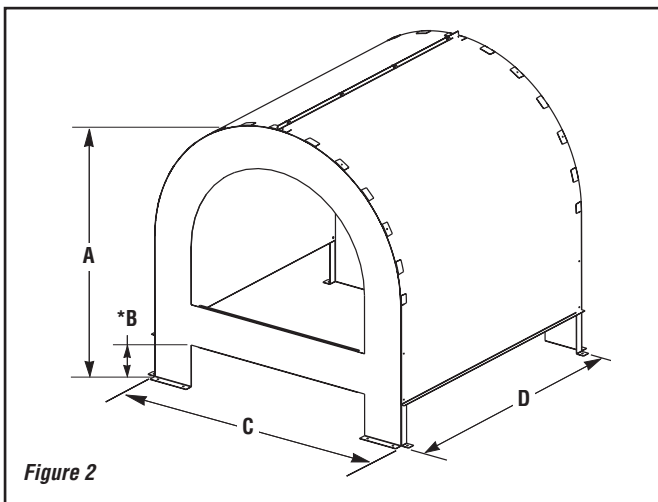

Figure 2

TOOLS NEEDED:

Tin Snips
Misc. Tools for securing field supplied nails, screws, etc.
Leather Gloves - Recommended

GENERAL INFORMATION

These decorative termination shrouds are intended for use with B-Vent, Direct-Vent and Wood Vent Terminations. Maintain clearances as specified on **Page 4** (see **Table 3**) and refer to the installation instructions supplied with the appliance and termination for the correct accessories to be used (some terminations do not include an instruction sheet). Check with your local building code agency before you begin your installation to ensure compliance with local codes, including the need for permits and follow-up inspections.

PLEASE RETAIN THESE INSTRUCTIONS FOR FUTURE REFERENCE. READ AND UNDERSTAND ALL INSTRUCTIONS AND WARNINGS IN THIS DOCUMENT BEFORE BEGINNING THE INSTALLATION.

These shroud kits are designed to ensure the minimum air gap and to provide the installer with an approved method of installation. The shroud must be constructed according to the minimum dimensions and installed as shown in this manual and the installation manuals provided with the appliance and termination.

The shroud kit components may be finished with high temperature enamel paint for added protection. **Do Not** remove or paint over the certification label inside the legs.

! WARNINGS

These shrouds are NOT approved to be cut down or modified in any way.

The shroud must be able to be removed after installation for cleaning and service of the chimney and termination.

The shroud must not Enclose Any Exhaust or Vent for other appliances.

Before you install the shroud, the termination must be installed according with the installation instructions provided with the termination.

Tested & Listed By  Beaverton Oregon USA OTL Report No. 116-F-34-5
OMNI-Test Laboratories, Inc.

Approved Wood Termination Caps:

The listed wood termination caps shown on this page are approved for use with these termination shrouds. No other brand of wood termination caps may be used. All clearances must be maintained as specified on **Page 4** and per the instructions provided with the termination cap.

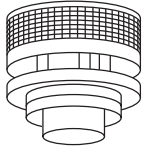

Contemporary Termination - Round

- 63L42 FTF8-CTD
- 63L43 FTF10-CTD
- 63L44 FTF13-CTD

Contemporary Termination - Round, Black

- H2238 FTF8-CTDP

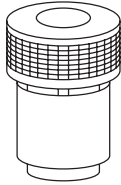

Chase Termination (Round)

- 63L45 FTF8-CTDT
- 63L46 FTF10-CTDT

750,014M

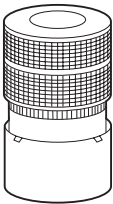

Chase Termination (Round)

- 63L47 FTF13-CTDT

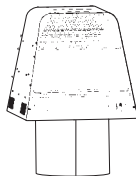

Arch Top Termination

- (For shrouds closed above) 96L22
- 96L23

- FTF8-ATT
- FTF10-ATT

750,036M

Approved Gas Direct-Vent Termination Caps:

Lennox, Security® and Simpson Dura-Vent® brand listed Direct-Vent gas termination caps are approved for used with these shroud kits. No other brand or model termination cap may be used. All clearances must be maintained as specified on **Page 4** and per the instructions provided with the termination cap.

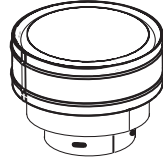

Secure Vent™ Direct-Vent Terminations by Security Chimneys International:

- H2265 SV8VTR 8" Inner / 11" Outer
- H2152 SV4.5CGV-1 4-1/2" Inner / 7-1/2" Outer

Simpson Dura-Vent® Direct-Vent Termination Kits:

- 923GK Termination Kit, Standard (Co-Linear, 3") - Adapts to 991 termination
- 930 Termination Kit, Extended Vertical 16-3/16" Height (Co-axial, 4" inner, 6-5/8" outer)
- 980 Termination Kit, Standard (Co-axial, 4" inner, 6-5/8" outer)
- 991 Termination Kit, High Wind (Co-axial, 4" inner, 6-5/8" outer)



**Lennox Hearth Products
Vertical Co-Linear (3") DV Termination Cap
H0908 TKDVI Vertical Term. Cap**

Approved Gas B-Vent Termination Caps:

Lennox, Simpon Dura-Vent® and Amerivent® brand listed gas termination caps (in sizes 4", 5", 6" & 8") are approved for used with these shroud kits including the termination caps in the following kits offered by Lennox Hearth Products. All clearances must be maintained as specified on **Page 4** and per the instructions provided with the termination cap.



**Lennox Hearth Products
H0906 VKBV125 Vent Kit, BVI, 4 x 25'
H0907 VKBV135 Vent Kit, BVI, 4 x 35'**

NOTE: DIAGRAMS & ILLUSTRATIONS ARE NOT TO SCALE.

**INSTALLATION INSTRUCTIONS
SHROUD ASSEMBLY**

Step 1. Assemble the shroud assembly as shown in **Figures 4 Through 7.**



Edges are sharp! Leather gloves are recommended.

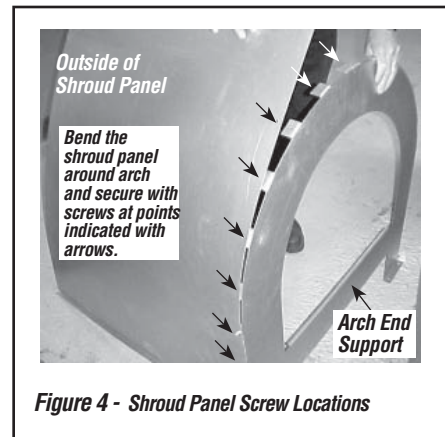
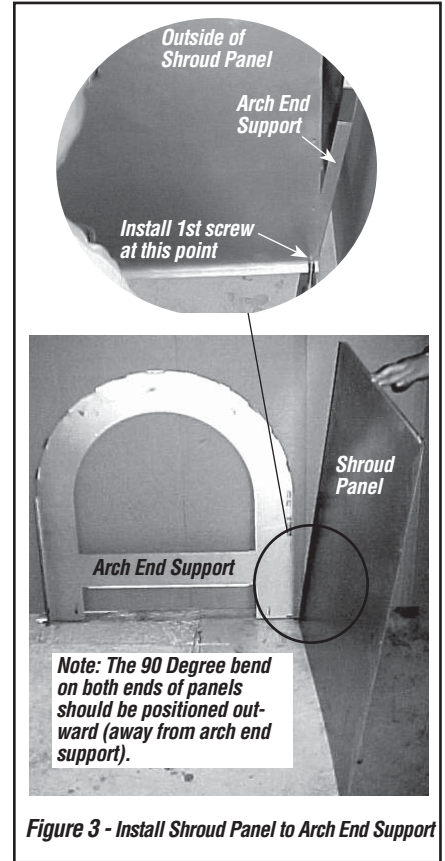

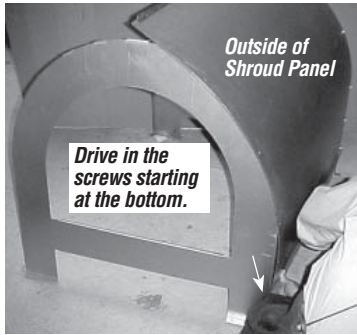

Repeat process from Figure 4 and secure shroud panel to the remaining arch end support panel as shown.



Figure 5 - Install Remaining Arch Support

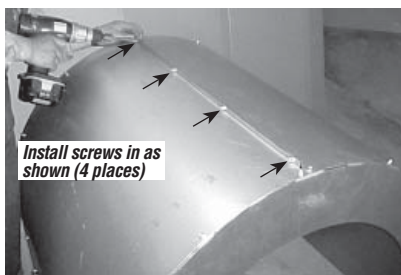

1. Repeat process from Figures 4 & 5 and secure the remaining shroud panel to the other side of arch end support panels as shown.

2. Secure top flanges on both shroud panels at the top of the arch as shown above.

Figure 6 - Install Remaining Shroud Panel

Completed Shroud Assembly

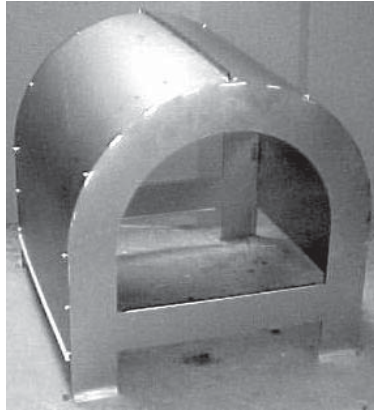

Component Identification

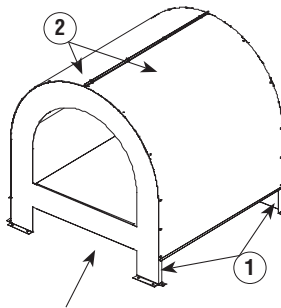

Do NOT block the 5" opening around the bottom of the shroud

1 = Arched End Supports
2 = Side Shroud Panels

Figure 7 - Completed Shroud Assembly

**INSTALLATION INSTRUCTIONS
CHASE FLASHING AND FLASHING
SPACERS:**

The chase flashing (fabricated locally) is used to anchor the termination and shroud to the chase. The flashing should be of a minimum 0.018" thick G90 galvanized steel or equivalent per ASTM 525 and should be constructed to overlap the chase and protect it from weather elements.

NOTES:

On existing construction, the flashing must be removed in order to install the spacers on some installations (read Step 1). A new flashing may be required to account for the extra height on the spacers (see Figure 10).

NOTE: DIAGRAMS & ILLUSTRATIONS ARE NOT TO SCALE.

Before proceeding, ensure the shroud will meet or exceed the minimum requirements for the termination cap you are going to install as shown in Figure 10.

- Step 1.** Secure the 1-1/2" flashing spacers, if applicable, to the top of the chase using nails or screws (See Figure 10). The flashing spacers (provided) **MUST** be used between the combustible chase top and the underside of the flashing to maintain 1-1/2" spacing for all wood termination caps excluding the FTF8-ATT & FTF10-ATT wood termination caps (see Page 2). The flashing spacers are NOT required with gas terminations.
- Step 2.** Install the chimney sections according to the instructions provided with the appliance.
- Step 3.** Mount the chase flashing over the spacers (if applicable). Secure to the chase with nails or screws (See Figure 10).
- Step 4.** Build the Shroud per the instructions on Pages 2 & 3.
- Step 5.** Install the shroud assembly and secure the legs to the flashing using three # 10 x 1/2" sheet metal screws for each leg.

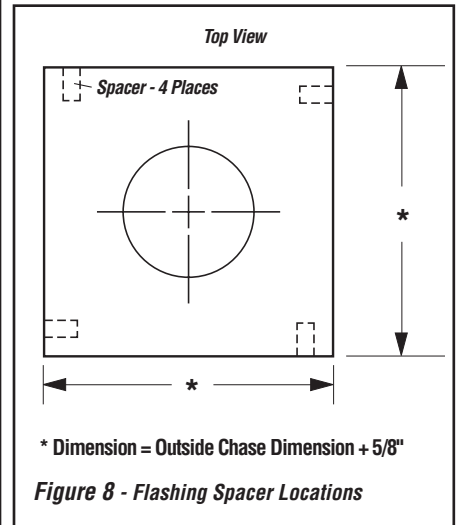

* Dimension = Outside Chase Dimension + 5/8"

Figure 8 - Flashing Spacer Locations

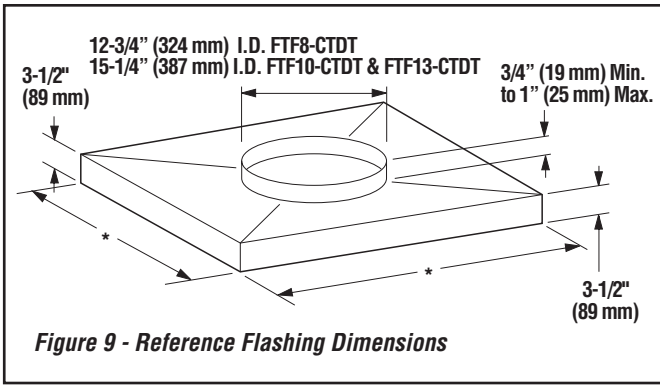

Figure 9 - Reference Flashing Dimensions

Notes:

* Dimension = Outside Chase Dimension + 5/8"

Note: Except where otherwise noted, all dimensions shown are minimums.

MINIMUM CLEARANCES - SHROUD WITH CLOSED TOP Refer To Figure 10				
Approved Wood Terminations				
Termination Type	A Minimum	B Minimum	C Minimum	D Minimum
FTF8-CTD FTF8-CTDT	34"	6"	8"	12"
FTF10-CTD FTF10-CTDT	34"	8"	8"	12"
FTF13-CTD	34"	8 3/4"	11"	12"
FTF13-CTDT	34"	8 3/4"	9-1/2"	12"
FTF8-ATT	34"	2"	2"	12"
FTF10-ATT	34"	2"	2"	12"
FTF8-CTT	NOT ALLOWED ON CLOSED TOP CONFIGURATIONS			
FTF10-CTT				
Approved Gas Terminations				
Secure Vent™ Direct-Vent Terminations by Security Chimneys International: SV8VTR, SV4.5CGV-1, SV4CGV, SV4FK, SV4FAK, SV4FBK, SV8VTR	34"	6"	8"	12"
Simpson Dura-Vent® Direct-Vent Termination Kits: 923GK, 930, 980, 991	34"	6"	8"	12"
AmeriVent® & Simpson Dura-Vent® and LHP kits: Cat. No.'s H0906 & H0907 (Approved B-Vent Caps in 4", 5", 6" & 8" Sizes)	34"	6"	8"	12"

Table 3

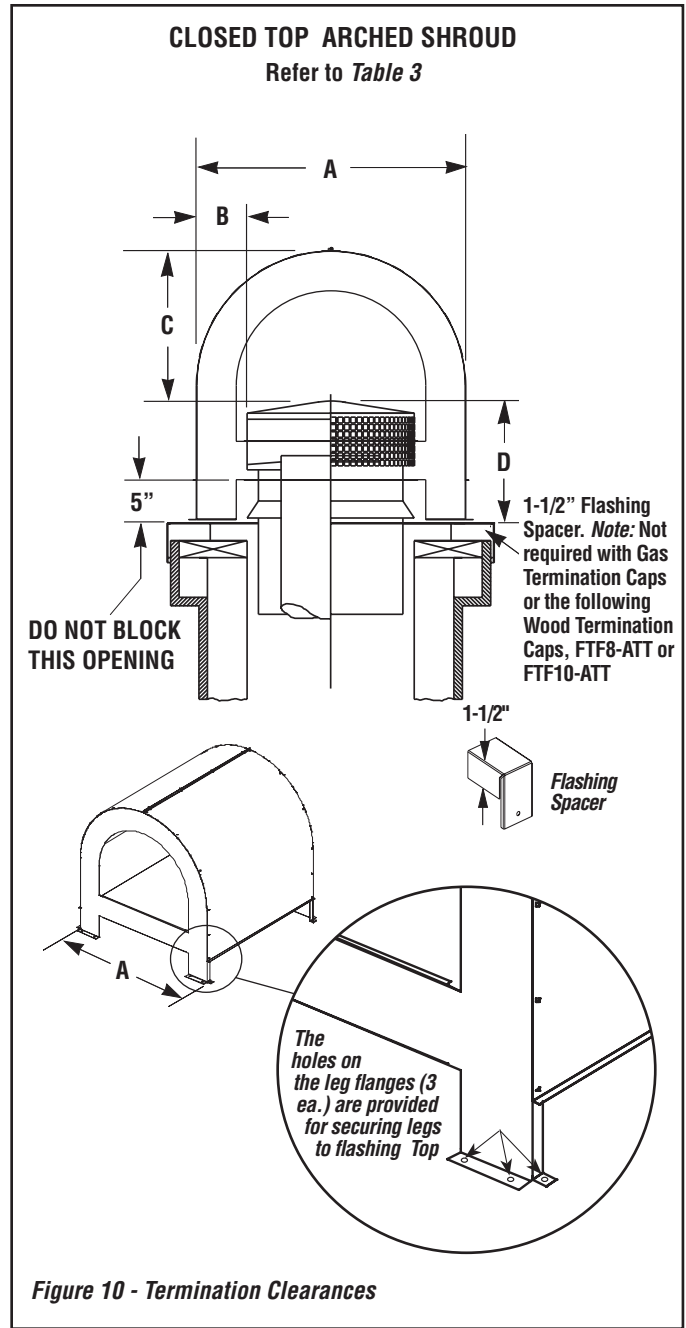

Figure 10 - Termination Clearances

NOTE: DIAGRAMS & ILLUSTRATIONS ARE NOT TO SCALE.

Lennox Hearth Products reserves the right to make changes at any time, without notice, in design, materials, specifications, prices and also to discontinue colors, styles and products. Consult your local distributor for fireplace code information.