



An economical and efficient workhorse that provides dependable pellet heating to keep any environment cozy and comfortable.

LENNOX
HEARTH PRODUCTS

MERIT[®] SERIES



Cascade™ stove shown with optional gold door

■ There's a good reason why thousands of homeowners can't live without the warmth of their pellet stove. The fuel burns efficiently, the heat is dense and effective and the burn times are long. The affordable Cascade™ pellet stove is the ideal introduction to this beloved heating method. The patented UltraGrate™ achieves nearly 100% fuel efficiency, while the generous 60-lb. hopper and automatic feed system deliver up to 30,000 BTUs per hour and can operate up to 40 hours. It's a great value that is as sure to perform as the winter is cold. ■

STANDARD FEATURES



1



2



3

STANDARD FEATURES

1. Large 60-lb. hopper capacity (shown with optional gold door)
2. Patented UltraGrate™ achieves nearly 100% combustion efficiency
3. Black cast-iron door

Dual-speed blower to control warmth delivered throughout the living space

High-efficiency automatic feed system

Delivers up to 30,000 BTU/hr*

Operates up to 40 hours on a single load of pellets
(BTUs and burn time vary with pellet type)*

Highly efficient heat exchanger with a built-in cleaning system

Large-capacity ash pan

Black finish

Full 2-year limited warranty on all electrical components

Backed by the Good Housekeeping Seal

OPTIONAL ACCESSORIES

Gold door

RELIABLE HEATING

With a generous 60-lb. hopper capacity and a high-efficiency automatic feed system, the Cascade™ pellet stove delivers up to 30,000 BTUs per hour and can operate up to 40 hours on a single load of pellets.* It is also equipped with a dual-speed blower, so you control the warmth distributed throughout your living area.

GREAT VALUE

The Cascade stove provides unparalleled performance at a great value. Our patented UltraGrate achieves nearly 100% combustion efficiency, allowing you to burn lower-grade fuels, even those with ash contents up to 2%. And with an exceptional efficiency of 78.8% and particulate emissions of 1.3 grams per hour, this stove is a clean and efficient bio-fuel heater that won't disappoint.

**Actual performance may vary depending upon home design and insulation, ceiling heights, climate, condition and type of fuel used, appliance location, burn rate, accessories chosen, chimney installation and how the appliance is operated.*

DIMENSIONS

| | |
|---------------|---------|
| WIDTH | 23" |
| HEIGHT | 28-3/8" |
| DEPTH | 21-3/4" |

CAPACITIES

| | |
|--------------------------|-------------------|
| HEATING CAPACITY* | 500–1,500 sq. ft. |
| BTU RANGE** | 12,600–30,000 |
| FUEL CAPACITY | 60 lbs. |
| BURN TIME*** | 17–40 hrs. |

*Square feet heating capacities are approximations only.

**BTUs vary with pellet type.

***The burn time will vary with size and type of fuel being used.

CLEARANCES

| | |
|-------------|----|
| BACK | 1" |
| SIDE | 4" |

EFFICIENCIES & FEDERAL EMISSIONS

EFFICIENCY 78.8%

EMISSIONS 1.3 gm/hr.

STATUS EPA Exempt

Cascade test results. Results based on EPA test methods. Efficiencies vary with fuel feed rates. They fulfill the Federal Emissions Standard—7.5 grams/hr. particulate maximum. UltraGrate™ U.S. patent #5137010, 5383446.

Cascade™ is approved for manufactured (mobile) home installation. This stove is manufactured and shipped with the UltraGrate™ installed, which enables it to burn both premium-grade and standard-grade wood pellet fuel with up to 2% ash content as defined by the PFI.

CASCADE™ DIMENSIONS

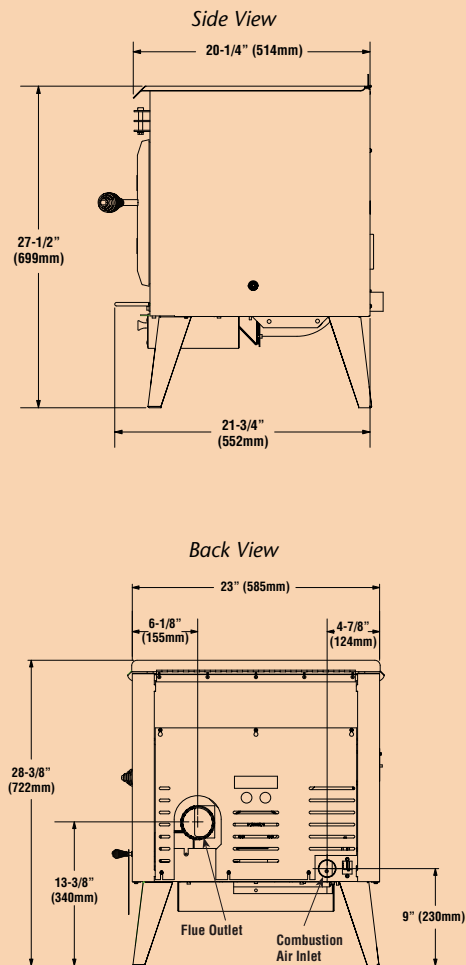

Dimensional Tolerance +/- 1/4".
Pipe locations measured to centerline.

PRODUCTS AND DEALERS YOU CAN COUNT ON

At Lennox, we understand how important it is for you to feel comfortable at home, so we're committed to providing you with the finest hearth products available. Choosing the right dealer for your hearth needs is every bit as important as choosing the right brand, and we think you'll agree that our dealers are a big reason why you can count on getting quality customer service when you call.

IMPORTANT NOTES:

As with any heating appliance, fireplace or stove, this appliance is extremely hot during operation. Read and understand all operating instructions before using this appliance. For further information, consult your dealer.

Diagrams, illustrations and photographs are not to scale—consult installation instructions. Product designs, materials, dimensions, specifications, colors and prices are subject to change or discontinuance without notice.

Approved to U.S. and Canadian safety and performance standards—ASTM E1509 and ULC C1482/ULC S627.

LENNOX
HEARTH PRODUCTS

© Lennox Industries Inc. 2011

Visit us at www.lennox.com, or contact us at 1-800-9-LENNOX.



Tested & Listed By **OMNI-TEST** Portland Oregon USA
OMNI-Test Laboratories, Inc.
Report number: 050-S-23-2



100% recycled